

The Measurement of Concentration and Temperature Distribution of Three Dimensional Transient Spray by Laser Interfero-Holographic and Tomographic Analysis

Y.C.Song, F.M.Shi, X.Y.Gao, F.C.Yan and J.H.Chen

*Institute of Internal Combustion Engine
Dalian University of Technology
Dalian, 116023
P.R.China*

ABSTRACT

This paper provides a new measuring technique to obtain the concentration and temperature field of a un-symmetrical three dimensional transient diesel spray by the laser interfero—holographic and tomographic analysis. The theory to get the concentration and temperature distribution of a spray by laser technique is stated in detail. The experimental installation and optical system are given concretely. Finally, the test results are analysed satisfactorily.

INTRODUCTION

Spray combustion is the main combustion approach in the diesel engine and some thermal installation using fuel burner. The concentration and temperature distribution of the diesel spray plays an important role in diesel ignition and combustion. The development of laser technique provides an advanced measuring tool to detect the concentration and temperature distribution of the fuel spray. Arcoumanis⁽¹⁾ adopted Rayleigh scattering technique to investigate the concentration and temperature field of a spray in an actual diesel engine. Dent⁽²⁾ used the laser interfero—holographic technique to measure the fuel spray distribution in a test bomb. But, all these studies were proceeded under two dimensional spray condition. In this paper, the measurement of the concentration and temperature field of the three dimensional transient diesel spray by the laser interfero—holographic and tomographic analysis is proposed and realized to provide an effective and complete measuring technique.

THEORY

The theory of the laser interfero—holographic and tomographic analysis to measure the concentration and temperature field of a three dimensional diesel spray is based on the interference fringes formed by two laser pulses, one pulse passes through a space with the ambient air, the other through the same space with the spray to be measured. The difference of the refraction index of the ambient air and the spray field, between two exposures of laser pulses are recorded by interference fringes. According to the relationship among refraction indexes, concentration and temperature by the Gladstone—Dale rule, the concentration and temperature field of the spray can be solved. Because of two laser pulses take same optical path, the quality of the optical elements and windows can be lowered. Also the operation of the experiment is convenient and the test results can be reserved forever for analysis.

The optical path difference between two laser pulses passing through the ambient air and the spray field is

$$\Phi = \int_L [n(x, y, z) - n_0] ds \quad (1)$$

where L —the distance penetrated by the laser

$n(x, y, z)$ — the refraction index of the spray field

n_0 —the refraction index of the ambient air. It correlates with the fringe order in the interfero—hologram as

$$\Phi = \lambda \cdot N \quad (2)$$

Here λ —wave length of the laser, N —fringe order. Actually, the interference fringes can be considered as the projection of the spray field along the laser direction. The reverse of Eq(2) can obtain the original spray field from

the projection. In fact, the reconstruction of the three dimensional spray field from the interfero-hologram is based on a number of interfero-holograms obtained from different laser directions, then to separate the three dimensional spray field into a set of parallel sections which will be reconstructed tomographically. So, the interfero-holographic and tomographic technique is nominated for such a kind of interfero-hologram reconstruction.

If a section $Z=Z_0$ is taken in a z direction as in Fig. 1, the optical path difference would be

$$\Phi(\rho, \theta) = \int_L [(n(x, y, z_0) - n_0)] ds \quad (3)$$

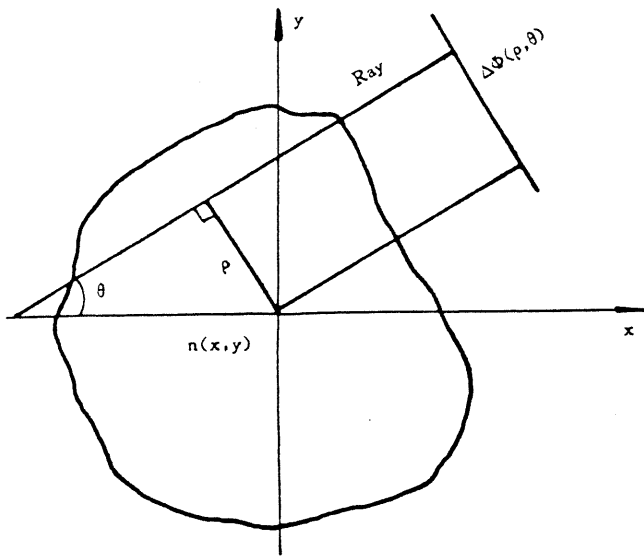

Fig. 1 The section of three dimensional spray field

Now, a suitable transformation⁽³⁾ is adopted as in Fig. 2, we have

$$\Phi(\rho, \theta) = \iint_{-\infty}^{+\infty} [n(x, y) - n_0] \delta[\rho - r \sin(\psi - \theta)] dx dy \quad (4)$$

Its reverse transformation⁽⁴⁾ is

$$n(r, \psi) - n_0 = \frac{1}{2\pi^2} \int_{-\frac{\pi}{2}}^{+\frac{\pi}{2}} d\theta \int_{-\infty}^{+\infty} \frac{\partial \Phi(\rho, \theta)}{\partial \rho} \frac{d\rho}{r \sin(\psi - \theta) - \rho} \quad (5)$$

Let $\rho_0 = r \sin(\psi - \theta)$ and assume the maximum radius in the $z=z_0$ section is R_{max} , then

$$n(r, \psi) = \frac{1}{2\pi^2} \int_{-\frac{\pi}{2}}^{+\frac{\pi}{2}} I(\theta) d\theta \quad (6)$$

Here,

$$I(\theta) = \int_0^{R_{max}} [\Phi(\rho_0 - \rho, \theta) + \Phi(\rho_0 + \rho, \theta) - 2\Phi(\rho_0, \theta)] \frac{d\rho}{\rho^2} - \frac{2}{3R_{max}} \Phi(\rho_0, \theta) \quad (7)$$

From (6), we can see that in order to obtain $n(r, \psi)$ it is necessary to acquire a number of interfero-hologram data from different observing angles within the range of π . If the observing angles with an equal interval are taken in the experiment, then

$$-\frac{\pi}{2} = \theta_0 < \theta < \dots < \theta_{2N-1} < \theta_{2N} = \frac{\pi}{2} \quad (8)$$

Apply Simpson approximate integration, we get

$$n(r, \psi) - n_0 = \frac{1}{12\pi N} \sum_{i=0}^{N-1} [I(\theta_{2i}) + 4I(\theta_{2i+1}) + I(\theta_{2i+2})] \quad (9)$$

The data $\{\Phi(\rho_i, \theta_i)\}$ obtained from the fringe location in the interfero-hologram are the discrete values which should be treated by curve fitting to get the values in Eq (7). In other words, if the different interfero-holograms have been got from different observing angles within the range of π and the fringe locations have been read in the interfero-holograms, then the change or the distribution of refraction indexes of the whole three dimension spray field can be deduced. Considering the precision and the amount of calculation, the observing angle with an equal interval $\theta = \frac{\pi}{6}$ is decided which may be the most suitable angle for computer simulation.

After the refraction index distribution of the spray field is determined, the concentration and temperature field can be calculated from following four equations⁽⁵⁾:

$$C_j = \left[\left(\frac{T_0}{T} - 1 \right) - \frac{n - n_0}{\rho_0 K_0} \right] / \left[\left(\frac{M_0}{M_j} - 1 \right) \left(\frac{n - n_0}{\rho_0 K_0} + 1 \right) - \frac{T_0}{T} \left(\frac{K_j}{K_0} - 1 \right) \right] \quad (10)$$

$$T = C_j T_s + (1 - C_j) T_0 \quad (11)$$

$$C_{ij} = \left(\frac{M_j}{M_0} \right) \left(\frac{P_{ij}}{P_T - P_{ij}} \right) / \left[1 + \left(\frac{M_j}{M_0} \right) \left(\frac{P_{ij}}{P_T - P_{ij}} \right) \right] \quad (12)$$

$$\frac{C_{ij}}{1 - C_{ij}} = C_p \frac{T_0 - T_i}{h_{f,ij}} \quad (13)$$

here n —the refraction index of fuel vapour

n_0 —the refraction index of air

K_j —G-D constant of fuel

K_0 —G-D constant of air

C_j —mass fraction of fuel

C_{ij} —mass fraction of saturated fuel vapour

M_j —molecular weight of fuel

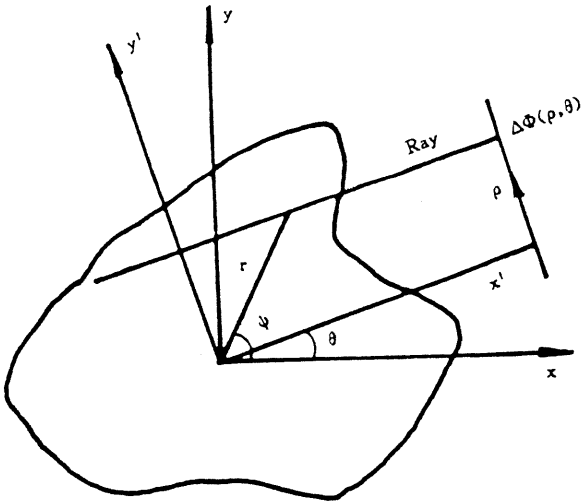

Fig. 2 The scheme of Radon transformation

- M_0 —molecular weight of air
- ρ_f —density of fuel
- ρ_0 —density of air
- T —temperature to be determined
- T_0 —initial ambient temperature
- T_s —saturated temperature at fuel surface
- P_u —saturated vapour pressure
- P_T —ambient pressure in the bomb

- C_p —average specific heat of fuel—air mixture
- h_{fg} —latent heat of fuel at saturated temperature T_s

There are four unknowns T_s , C_{ij} , C_j and T in the four equations. After solving simultaneously, C_j and T can be found.

EXPERIMENTAL SET AND OPTICAL SYSTEM

Fig 3 shows the experimental set.

The DC motor 1 drives a fuel pump 6, which pumps the high pressure fuel to an injector 10 through a pipe 9. The control system 13 and the electro—magnetic controller of the fuel pump rack 7 manipulates the single pulse injection and the amount of fuel injected respectively. The combination of the control system 13 and an angle indicator 12 can determine the time of laser pulse emitted. The gas temperature in the bomb can be heated by electric heater 20, which is adjustable by a regulator 14 through changing the terminal voltage across the heat resistance. The cooling water, led by a water jacket joint 11 prevents the air block in the injector after heating the bomb. The gas temperature and pressure is monitored by a thermocouple 17 and a gauge 16.

Fig. 4 indicates the optical set of the laser interfero-holographic and tomographic system.

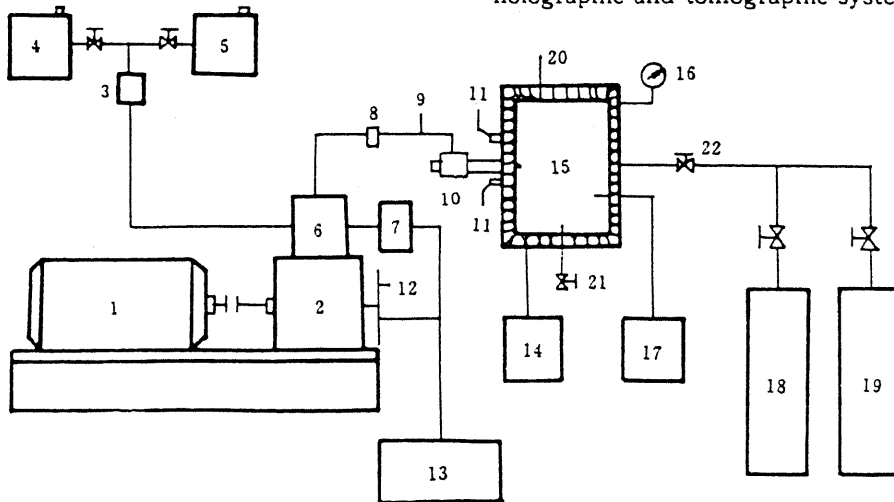

Fig. 3 The scheme of experimental set

- 1. DC motor 2. fuel pump camshaft 3. filter 4. n—neptane 5. diesel fuel 6. fuel pump 7. electromagnetic controller 8. pressure sensor 9. fuel pipe 10. injector 11. joint of cooling jacket 12. angle indicator 13. control system 14. temperature regulator 15. high pressure and temperature bomb 16. pressure gauge 17. Thermal couple 18. high pressure air bottle 19. high pressure nitrogen bottle 20. electric heater 21. exhaust valve 22. intake valve

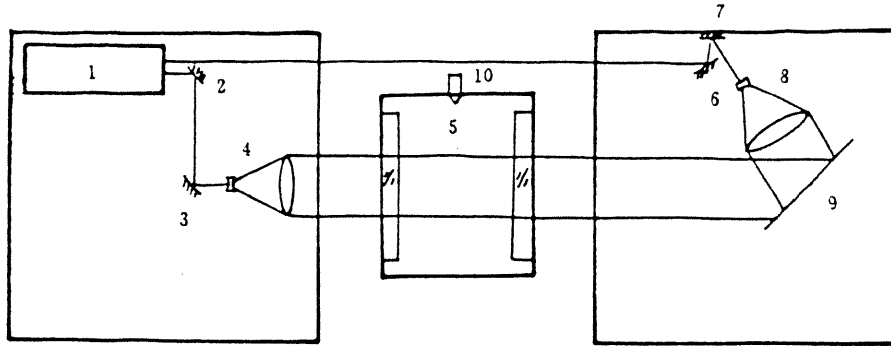

Fig. 4 The optical set of the laser interfero-holographic and tomographic system.

1. double pulse ruby laser 2,3,6,7 reflecting mirror 4,8. expander-collimator set 5. high pressure bomb
9. holographic film 10. injector

THE IMAGE PROCESSING OF LASER INTERFERO-HOLOGRAM

Because of the environmental disturbance in the experiment the interfero-hologram of the spray, the laser interfero-holographic and tomographic technique always bring in some unavoidable noise level. It will make great difficulty to calculate the concentration and temperature field from the interfero-holograms. In order to solve this problem, a system of image processing by a computer to process the interfero-hologram is developed. Fig. 5 shows the block diagram of the system. The main points of the system are:

- (1) reduction of noise by K - most neighboring weighting average method
- (2) image enhancement by histogram equalized

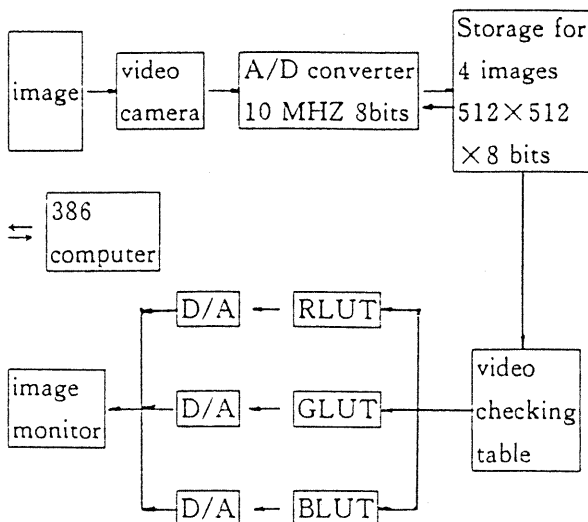

Fig. 5 The block diagram of image processing system

(3) multi-threshold method to keep the object separated from the background

(4) three point imitation curve method to thin the lines

After these approaches have been adopted, the clear images are received.

EXPERIMENTAL RESULTS AND ANALYSIS

In order to obtain a three dimensional concentration and temperature distribution, we measure the overlapping zone of two adjacent hole sprays of a medium speed locomotive diesel injector. In these types of diesel engines, the inlet swirl is relatively lower, therefore the mixing rate and combustion is more dependent on the fuel distribution, atomization and evaporation. The measurement of the concentration and temperature field of two adjacent hole sprays will make contribution to study the mixture formation, ignition and combustion of the low and medium speed diesel engine. Table 1 lists the specifications of the injector.

Table 1 specifications of injector

Diameter of fuel pump plunger	Ø18mm
Hole diameter of injector	Ø0.3mm
valve opening pressure of injector	25.5MPa

Fig. 6 illustrates the coordinate system of the experiment. The hole of the injector is located at 0 and the axis of injector is perpendicular to the Z plane. The interfero-

holographic pictures will be taken consecutively from seven directions with an equal angle interval $\frac{\pi}{6}$ ($\theta = -\frac{\pi}{2}, -\frac{\pi}{3}, -\frac{\pi}{6}, 0, \frac{\pi}{6}, \frac{\pi}{3}, \frac{\pi}{2}$). Because of symmetry in the plane, it only needs to take pictures in four directions ($\theta = -\frac{\pi}{2}, -\frac{\pi}{3}, -\frac{\pi}{6}, 0$) to get whole information of the original field. During the experiment, only the injector is revolved $\frac{\pi}{6}$ after finishing one operation in order to keep the optical set unmoved. Fig. 7 presents the interfero-holograms when $\theta=0$ (ambient temperature 453K, ambient pressure 0.1MPa)

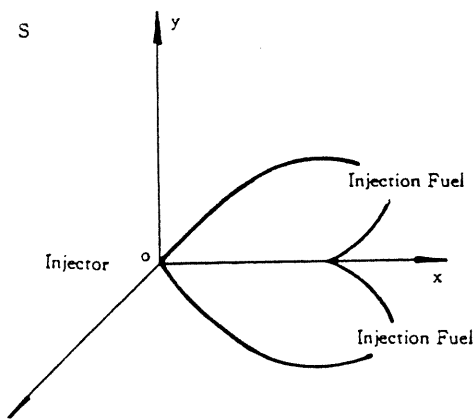

Fig. 6 The coordinate system of the experiment.

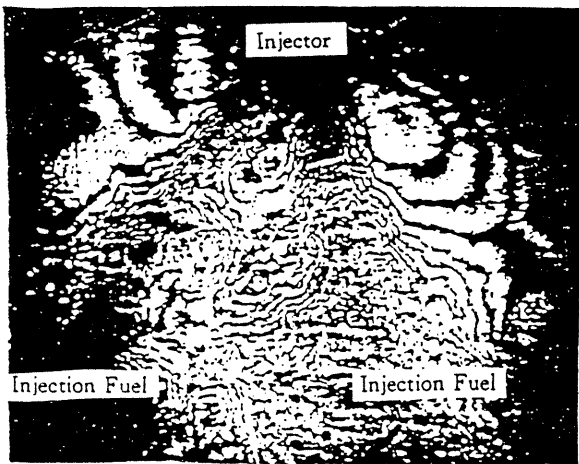

Fig. 7 The interfero-hologram, $\theta=0$

Fig. 8 are the interfero-holograms of Fig. 7 respectively after interference fringe processing.

Now, take $z=10\text{mm}$, $z=15\text{mm}$ and $z=20\text{mm}$ three sections to acquire the data and calculate the concentration and temperature distribution of two adjacent sprays. First, read $N(\rho_i, \theta_i)$ on the interfero-hologram at a different angle direction in the demanding section. According to Eq (2), find out $\Phi(\rho_i, \theta_i)$, then make curve fitting and substitute into Eqs(7), (9) to obtain the difference of refrac-

tion index $n - n_0$. Finally, solve Eqs(10), (11), (12) and (13) simultaneously to get concentration C_i and temperature T . Fig. 9~Fig. 11 show the iso-concentration and isotherm in three sections ($z=10, 15, 20\text{mm}$) at ambient temperature 453K and ambient pressure 0.1MPa.

From these figures, some rules can be observed that the temperature of the spray is increased with the increase in the radial distance, but the concentration is decreased. Both the concentration and temperature gradients are decreased with the increase in the radial distance. As the spray pushing forward, the cross-sectional area will be expanded and more air is entrained to decrease the concentration and to increase the temperature. Nevertheless, the concentration and temperature gradient along the radial direction will be decreased as the spray penetrating forward. The concentration and temperature of the overlapping zone of two adjacent sprays is commonly influenced by two sprays especially near the injector hole. So, the concentration of the sprays near the injector hole are greater than the far end.

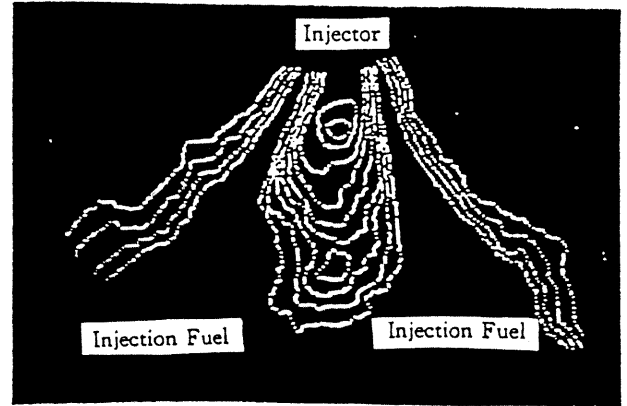

Fig. 8 The interfero-hologram of Fig. 7 after image processing

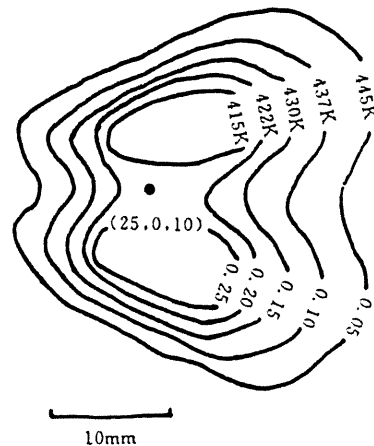

Fig. 9 Isoconcentration and isotherm of two adjacent sprays in the section, $z=10\text{mm}$

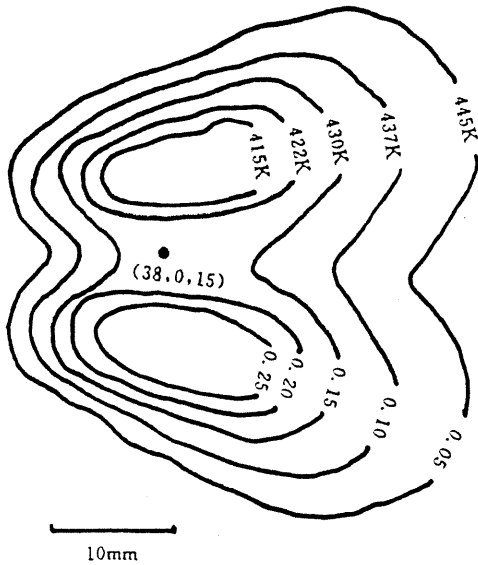

Fig. 10 Isoconcentration and isotherm of two adjacent sprays in the section, $z=15\text{mm}$

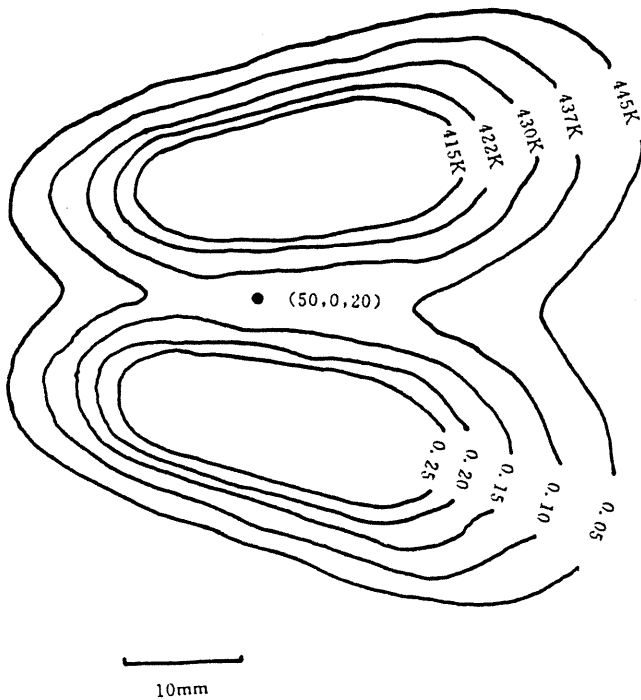

Fig. 11 Isoconcentration and isotherm of two adjacent sprays in the section, $z=20\text{mm}$

SUMMARY

(1) The measurement of the three dimensional concentration and temperature field of the transient spray by the laser interfero—holographic and tomographic technology is a very effective measuring approach.

(2) The delicate design of the experimental installation including the optical system and the reconstruction system makes the whole set to meet the measurement of the three dimensional transient spray satisfactorily. The improvement of laser module output and precise image processing of the interfero—hologram provides the good conditions to run the experiment smoothly and to get the better results.

(3) When the spray moves forward, the concentration of the spray will decrease with the increase in the radius of the spray, but the temperature variation just opposite. Their gradients are decreased with the increase of the spray radius. The multi—hole injector will create an overlapping zones between two adjacent hole sprays. These zone will be larger near the injector.

(4) As the ambient temperature rises, the concentration near the spray axis will decrease and the temperature will increase. The overlapping zone of two adjacent hole sprays will increase. Both the increase in the temperature near the spray axis and the overlapping zone are less than that of ambient temperature.

REFERENCES

- [1] Arcomanis, C. , " The Application of laser Rayleigh Scattering to Reciprocating Model Engine" , SAE Paper 840376 1984.
- [2] Dent, J. C. , " Interferometric studies of Vapourising and Combustion Spray" , SAE Trans 830244 1983.
- [3] Archbold, E. , " Displacement measurement from double-exposure laser photographs" , Opt. Acta, 19, 1972.
- [4] West, C. M. , Holographic Interferometry, New York 1979.
- [5] Dent, J. C. , " The Application of Interferometry to Air Fuel Ratio Measurement in Quiescent Chamber Diesel Engines" , SAE Paper 770825 1977.