

Influence of Fuel Spray Impingement on Combustion in a D.I. Diesel Engine

K.Takasaki, Y.Wakuri*, K.Maeda**, T.Oyamada*** and K.Hamasaki****

*Department of Mechanical Engineering
Kyushu University
6-10-1, Hakozaki, Higashi-ku, Fukuoka-shi 812
Japan*

** Fukuoka University*

*** Shimonoseki University*

**** Kyushu Kyoritsu University*

***** Kagoshima University*

ABSTRACT

In the present paper, various effects of the fuel spray impingement onto a piston on the fuel spray distribution and combustion in the combustion chamber of a medium speed direct injection type diesel engine were examined.

Investigations were carried out, not only with the operation data of the test engine, but also by the aid of visualization of the fuel spray combustion in both the specially developed single compression machine and the test engine.

As results, how the combination of fuel spray impingement and air swirl affects the spray distribution and combustion was made clear. Especially, some differences of its effect depending on the type of injection system (central-injection system or side-injection system) and on the kind of fuel (marine, diesel oil or bunker fuel oil) were newly clarified.

1. INTRODUCTION

To realize the optimum combustion in the combustion chamber of the direct injection type diesel engine, the effective and rapid use of the confined air is the most important problem to be solved. The conventional and reliable solution is to utilize sufficiently the mobility of the fuel spray and to disperse effectively the spray jet by air swirl. Despite many efforts (1)~(3) to solve this problem, the fundamental part of the problem is still not clear.

In the present paper, the authors paid attention to the impingement of fuel spray onto the piston, as a means to utilize the fuel spray momentum to disperse the fuel itself and in combination with the swirl, to realize the wide distribution of fuel in the combustion chamber.

Investigations about the effects of the fuel spray impingement were carried out not only with the operation data of the test engine, but also by the aid of visualization of the fuel spray combustion in both the specially developed single compression machine and the test engine.

2. EXPERIMENTAL APPARATUS AND PROCEDURE

2.1 Single Compression Machine

Two experimental rigs were prepared. One is a single compression machine for the

visualization of a single spray and the analysis of the heat release, and the other is a test engine for both the usual operation and the visualization of burning sprays.

The scheme and specification of the single compression machine are shown in Fig.1. A crank mechanism driven by an electric motor is used for reciprocation of the piston. At first, the piston is steadily reciprocated without compression with valve 8 open. The single compression is made by closing valve 8 by hydraulic power. The air pressure and the temperature at the beginning of compression can be set exactly by adjusting the air conditions in tank 5.

A swirling flow can be caused in the cylinder by valve 8 set in the circumferential direction. The profile of swirl velocities at the end of compression measured by tracing the small flames moving with the swirl is shown in the figure.

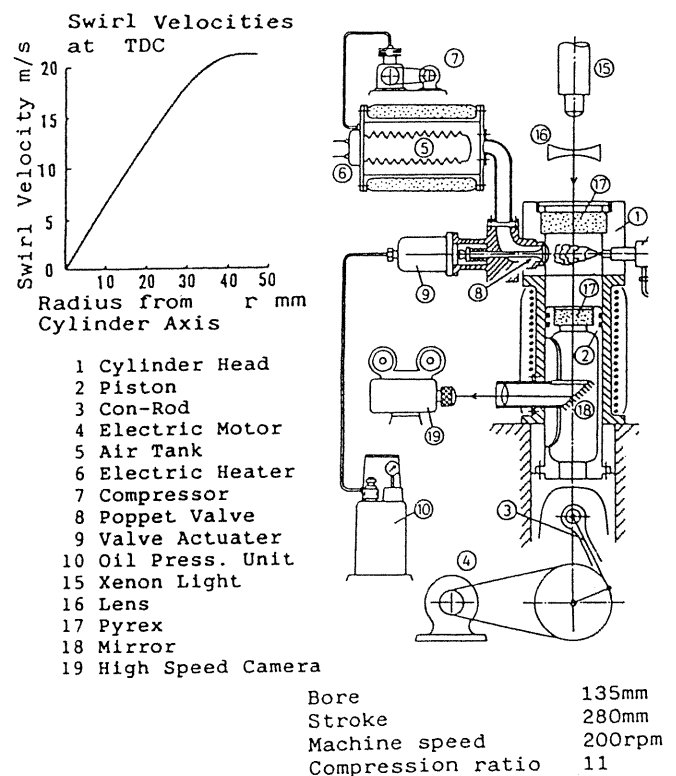

Fig.1 Single compression machine

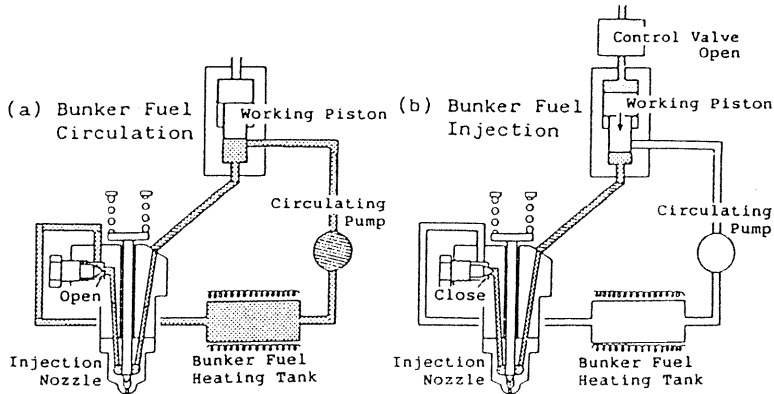

Fig. 2 Fuel injection system for the single compression machine

Four Pyrex-glasses were fitted at the top and on the two sides of cylinder head and at the top of piston. High speed photographs (7000 frames/sec.) were taken from side and underside of the combustion chamber. Two kinds of photographic techniques, shadowgraph and back diffused light method were applied. The outline of spray including the gaseous part can be observed by the former technique. On the other hand, only the liquid part of the spray is photographed before ignition by the latter technique. The scheme of fuel injection system installed in the single compression machine is shown in Fig. 2. This system has a plunger actuated by hydraulic power, and a high injection pressure (100 MPa) can be obtained with a relatively low hydraulic pressure (40MPa) owing to the difference of areas between the plunger and hydraulic piston. In the case with heated fuel, the fuel was circulated through the tip of injection nozzle in advance of injection so as to maintain the fuel temperature at a prescribed value as shown in Fig. 2(a). Just before the injection, the circulating line was closed as shown in Fig. 2(b). The fuel temperature in the nozzle tip was monitored by an inserted thermocouple even during the injection. In this study, a single hole nozzle with 0.3 mm dia. was installed on the side of combustion chamber, and fuel was injected for about 5 ms.

2.2 Test Engine

A sectional view and specification of the test engine are shown in Fig. 3. Alterations of swirl intensity can be made by the variable angle swirler installed around the scavenging ports as shown in Fig. 3. The swirl intensity at the beginning of compression stroke is represented by the sine of swirl inflow angle, $\sin\theta$.

The profile of swirl velocities at the end of compression measured by tracing the small flames moving with the swirl is shown in Fig. 4.

Conditions of both the operation test and the visualization test are shown in Table 1. In the visualization test, the engine was driven by the auxiliary external power, and fuel was injected only in the period of high speed photographing for preservation of the transparent piston. Cross sections of combustion chamber for the operation test and the visualization test are shown in Fig. 5. In this study, (a) the central injection system, coupled with the flat

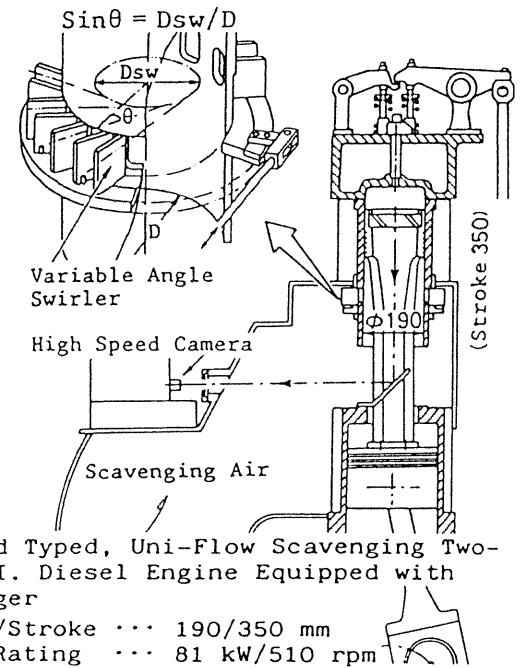

Fig. 3 Test engine

Bore/Stroke ... 190/350 mm
Max. Rating ... 81 kW/510 rpm
Max. Pme ... 0.98 MPa

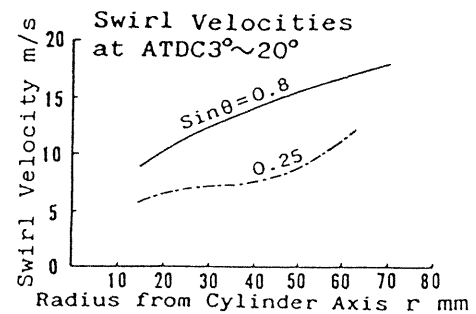

Fig. 4 Profile of swirl velocities in the engine

Central-Injection System Side-Injection System

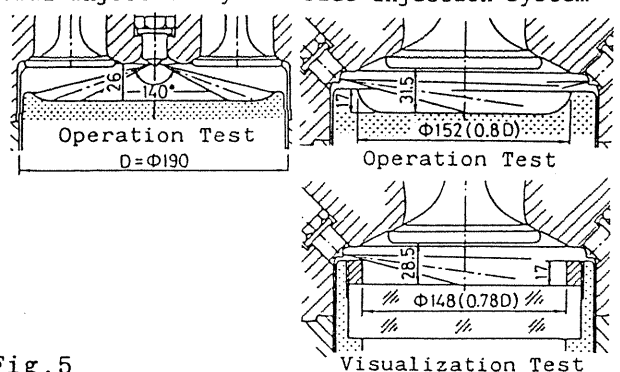

Fig. 5 Combustion chambers of the test engine

piston and (b) the side injection system, with two injection nozzles on the both sides of combustion chamber, coupled with the piston with a flat-bottomed bowl were adopted.

Fuel was injected during BTDC 5° ~ATDC 13° with injection pressure of 55 MPa in all the cases including the visualization test.

2.3 Test Fuel

Two kinds of fuel, marine diesel oil and bunker fuel oil were prepared for the study.

Table 1 Test conditions

	Operation Test	Visualization Test
Output/Pme	70.6kW/0.875MPa	Amount of fuel injected per cycle is equivalent to the operation test
Engine Speed	488rpm	430~440rpm
Compression Ratio	12	13
Scav. Press./Temp.	0.168MPa/303K	0.181MPa/333K
Excess Air Ratio	1.6~1.7	1.4

Table 2 Fuel properties

	Marine Diesel Oil	Bunker Fuel Oil
Density (15°C)kg/m ³	843	974
Kinematic Viscosity (50°C)mm ² /s	2.5	165.5
Flash Point °C	72	92
Wt% C	86.1	85.5
Wt% H	13.0	11.0
Wt% S	0.84	3.3
Residual Carbon Wt%	0.07	13.7
Lower Calorific Value KJ/kg	42500	40530

Specifications of injection nozzles

(a) Central-Injection System

	Number of Nozzle Holders	Number of Nozzle Holes	Hole Diameter mm
Operation Test	1	7	0.29

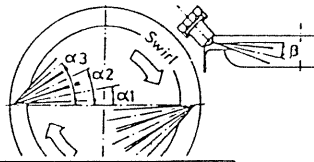

(b) Side-Injection System

	Number of Nozzle Holders	Number of Nozzle Holes	Hole Diameter mm	Hole Angle deg			
				alpha 1	alpha 2	alpha 3	B
Operation Test	2	3(x2)	0.31	10	25	40	12.5
Visualization	2	3(x2)	0.31	10	25	40	9

Properties and distributions of distillate components of these are shown in Table 2 and Fig.6. In Fig.6, the column marked ">500" of the bunker fuel oil shows the residual component whose distillation temperature is higher than 500°C under the atmospheric pressure. At the injection, the bunker fuel oil was heated to 105°C to have a viscosity of 20 cSt.

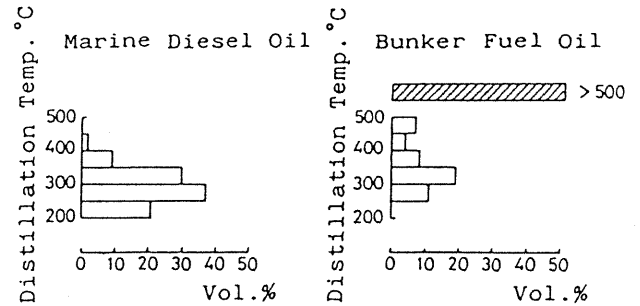

Fig.6 Distribution of distillates in test fuels

3. EXPERIMENTAL RESULTS

3.1 Influence of Fuel Spray Impingement on Combustion

Fig.7 shows the shadowgraph of the marine diesel oil spray taken from the side window of the single compression machine. Pressure and temperature of the air at fuel injection are shown in the figure as Pc and Tc.

In this figure, (a) shows what we call "free spray", the case that a fuel spray has been injected into the quiescent air in horizontal direction to avoid the impingement onto the piston. On the other hand, (b) shows the case of injection in 17.5° downward direction to impinge onto the piston. In both cases, ignition has occurred about 2 ms after the start of fuel injection.

Comparing the two cases 3 ms after the start of injection, flame (b) looks burning more "actively" than flame (a) owing to a larger flame volume. And 5.4 ms after the start of injection, it can be observed that the flame (b) has a strong rolling motion as shown in the figure beside the photograph. This effect is not seen in the flame (a).

Fig.8 shows the shadowgraph taken from the underside of the piston. In this figure, (a) and (b) have the same conditions as Fig.7 (a) and (b), that is, horizontal and downward injection into the quiescent air respectively. On the other hand, Fig.8 (c) and (d) show the horizontal and downward injection into the swirling air respectively.

Shadowgraph Marine Diesel Oil (Inj.Nozzle Hole Dia. 0.3mm, Inj.Press. 100MPa, Pc = 4.4MPa, Tc = 420°C)

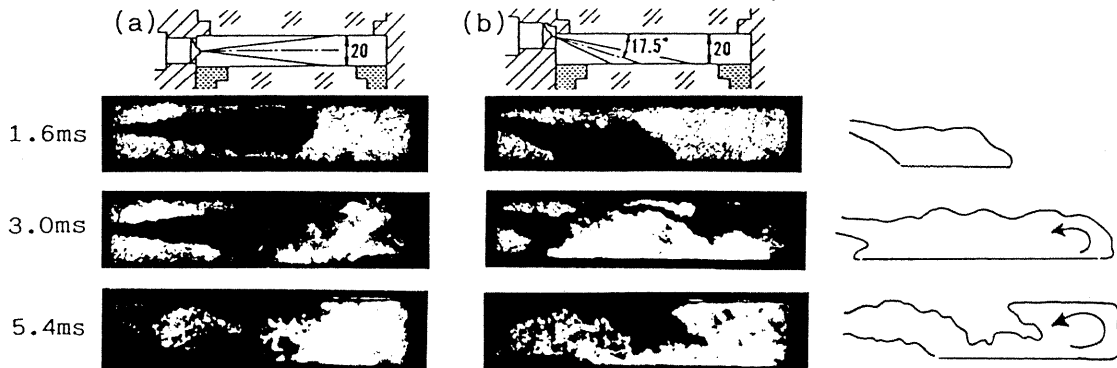

Fig.7 Sideview of spray/flame in the single compression machine (Shadowgraph, Marine diesel oil)

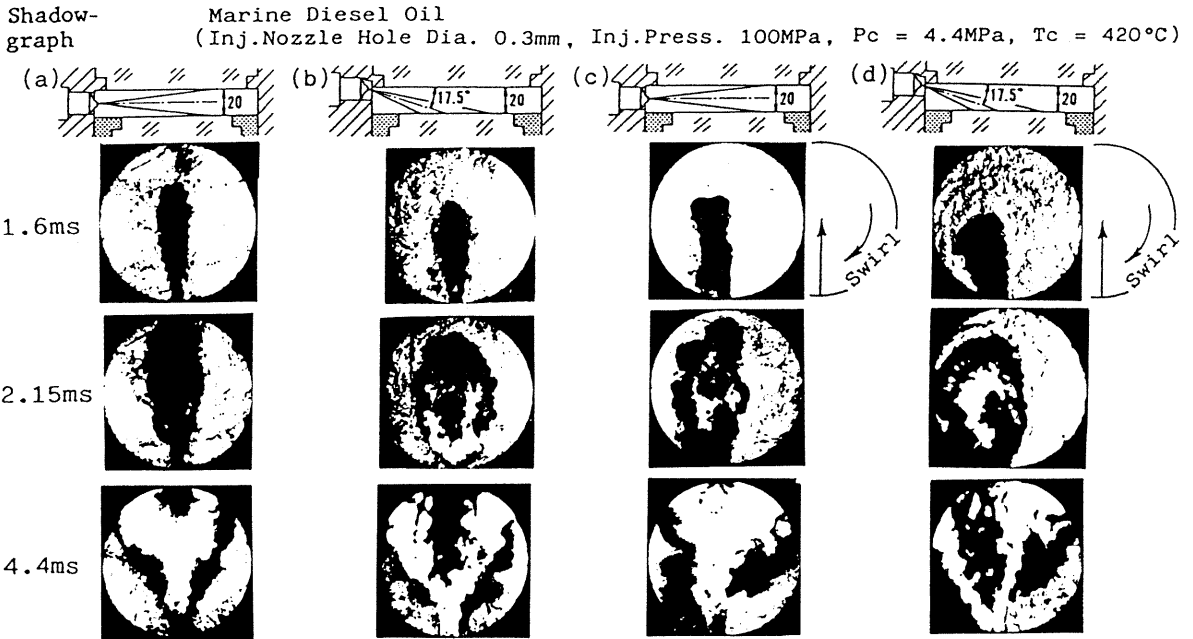

Fig.8 View of spray/flame from underside of the single compression machine (Shadowgraph, Marine diesel oil)

Comparing (a) and (b) in Fig.8, it is seen that 2.15 ms after the start of injection, the spray (b) spreads more broadly after the impingement than spray (a). Influence of the impingement on the distribution of the spray by the swirl can be observed by comparing (c) and (d). The spray (d) is distributed more widely in circumferential direction (clockwise), maybe because the spray speed in the direction of spray axis is slowed down and the fuel can be taken by the swirl more easily.

The influence of the spray impingement on combustion can be examined by the heat release rate. Fig.9 shows a typical heat release rate of a single spray in the single compression machine. In this figure, "ta" shows the period of pre-mixed combustion and "tb" shows the period of diffusive combustion. Released heat during "ta" and "tb" are expressed as Q_a and Q_b respectively.

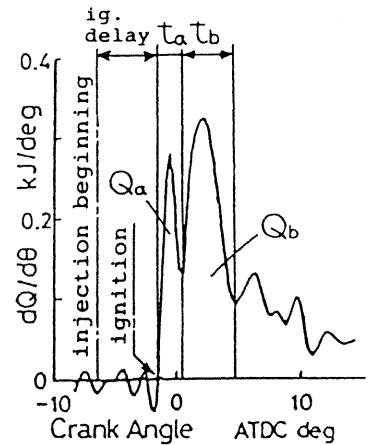

Fig.9 Typical heat release rate

The characteristics of the pre-mixed combustion is represented by Q_a/t_a , the mean heat release rate during "ta". The combustion characteristics from the ignition till the end of diffusive combustion is represented by the mean heat release rate during the total period, $(Q_a+Q_b)/(t_a+t_b)$.

Q_a/t_a and $(Q_a+Q_b)/(t_a+t_b)$ under the various conditions are shown in Fig.10. In any case of impinged spray in this experiment ignition has occurred after the impingement. In Fig.10, Q_a/t_a of impinged sprays are rather lower than the "free sprays" in both cases with and without swirl. It means that the impingement would not help the pre-mixed combustion. On the other hand, $(Q_a+Q_b)/(t_a+t_b)$ of impinged sprays are clearly higher than the "free sprays". Especially, impinged sprays in the swirl show highest $(Q_a+Q_b)/(t_a+t_b)$. According to such results, it has become clear that the impingement has an effect on the diffusive combustion.

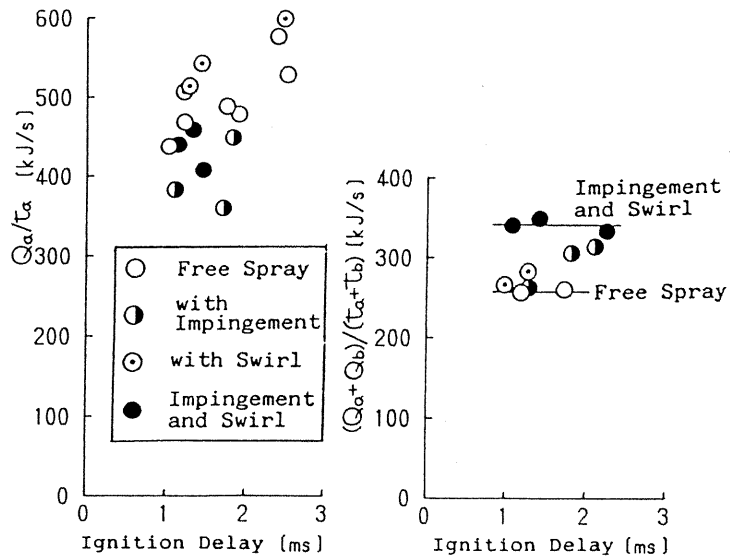

Fig.10

Arrangement of data with mean heat release rate (Single compression machine)

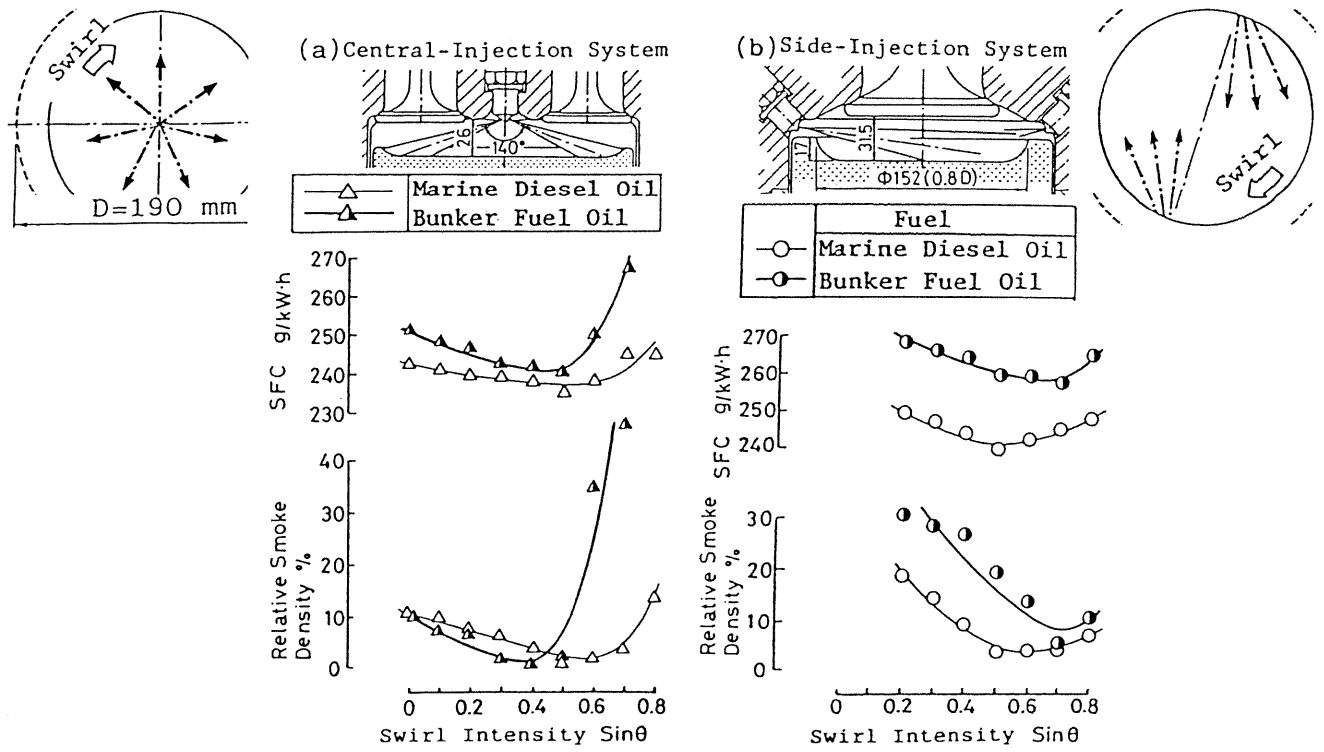

Fig.11 Performance of test engine

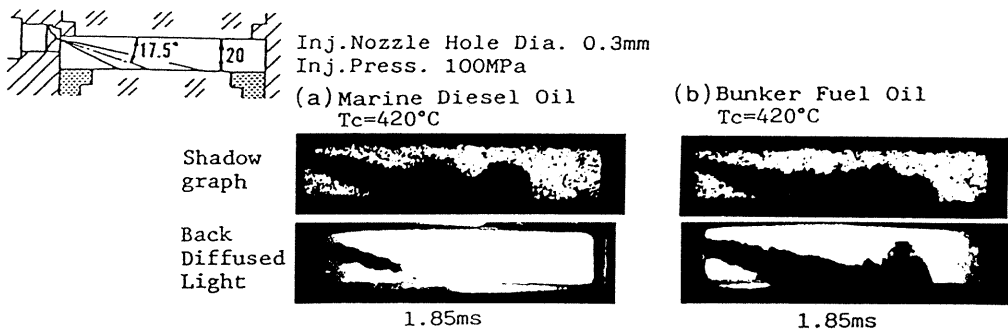

Fig.12 Change in spray characteristics with fuel properties (Single compression machine)

3.2 Influence of Fuel Spray Impingement on the Bunker Fuel Combustion

Fig.11 shows a comparison of experimental results by the test engine using marine diesel oil (MDO) and bunker fuel oil (BFO) whose properties are given in Table 2. The data are shown as the change in exhaust smoke density and specific fuel consumption (SFC) in relation to the swirl intensity. In this figure, (a) shows the results under the central-injection system and (b) the ones under the side-injection system.

Fig.11(a) clearly indicates that the use of BFO may easily result in the "over-swirl" state, i.e. increase in smoke and SFC caused by unfavorable over-lapping of spray or flame to neighboring spray, with smaller swirl intensity than MDO under the central-injection system. On the other hand, in case of the side-injection system (Fig.11(b)), it is seen that the optimum swirl for BFO changes to higher intensity than that for MDO. ($\text{Sin}\theta = 0.5 \rightarrow 0.7$) This is apparently in contrast to the fact observed under the central-injection system.

To clarify the reason for the difference in the optimum swirl intensity between MDO and BFO, some observations of combustion in

both the single compression machine and the test engine were carried out.

Fig.12 shows the photos of MDO and BFO sprays in the single compression machine taken by the shadowgraph technique and back diffused light method. Comparing the two fuels, the following difference in the unevaporated liquid part of spray can clearly be observed with the back diffused light technique. Firstly, according to the photo of MDO spray, the liquid part of MDO spray does not touch the piston surface at all, though the evaporated gaseous part seen in the shadowgraph is already going ahead along the piston surface. That means all of the fuel has evaporated before the impingement.

On the other hand, the photo of BFO spray by the back diffused light method shows that the liquid part has impinged directly onto the piston. It might be because, for the residual portion in BFO, whose distillate temperature is higher than the air temperature, it is absolutely impossible to evaporate before the ignition of the light distillate portion.

Considering such the difference of the spray characteristics between the two fuels, the reason for the fact in Fig.11(a), that BFO sprays fall into the over-swirl state

with rather smaller swirl intensity under the central-injection system can be explained as follows. In the case of BFO, more or less, liquid fuel impinges and clings to the piston surface and would keep on evaporating there even after the end of fuel injection. Assuming such a model of the spray motion by the swirl after the end of fuel injection as in Fig.13, it is considered that BFO flames easily overlap the neighboring liquid film of fuel (Fig.13(b)), compared with MDO flames which would turn around chasing each other without overlapping ((Fig.13(a)).

The difference in the result of engine operation between the two fuels under the side-injection system in Fig.11(b), though it is apparently contrary to the result under the central-injection system, can be explained by the same reason. Fig.14 shows the direct photos of MDO and BFO flames under the same swirl intensity in the test engine with the side-injection system, whose specifications are exactly same as the operation tests. In these photos, ATDC 5° is the timing just after the impingement. Comparing the two fuels, BFO spray looks less distributed in circumferential direction by the swirl than MDO spray during ATDC 5°~10°. This might be because some part of BFO spray impinges and clings onto the piston surface in a liquid state. These photos correspond to the results of Fig.11(b), that BFO needs higher swirl intensity than MDO.

4. CONCLUSIONS

Considering about the results of engine operation test and photos taken in the single compression machine and the test engine, the following conclusions were derived.

- (1) An effect of fuel spray impingement is to enlarge the flame volume and improve the diffusive combustion.
- (2) Another effect of fuel spray impingement is to slow down the spray speed in the direction of spray axis and to realize the wide distribution of the fuel by the air swirl.
- (3) In the case that the bunker fuel oil is used, the optimum swirl intensity shifts from the case with the marine diesel oil, because of the impingement of the unevaporated liquid part of the bunker fuel spray onto the piston.

ACKNOWLEDGMENT

The authors wish to thank MITSUBISHI OIL Co., Ltd., MITSUBISHI HEAVY INDUSTRIES Co., Ltd., and YANMAR DIESEL Co., Ltd., for their kind cooperations. At the same time, the authors thank Dr.Y.Yang, Mr.S.Abe, Mr.S.Inoue, Mr.K.Yokohama and Mr.M.Shibakawa for their experimental work.

REFERENCES

1. WAKURI, Y., ONO, S. and TAKASAKI, K. "Influences of Air Swirl on Fuel Spray Combustion in a Marine Diesel Engine" ASME FED-Vol.28(Book No.G00312), pp47-55, 1985.
2. WAKURI, Y., TAKASAKI, K., and YANG, Y. "Studies on the Fuel-Spray Combustion Characteristics in a Diesel Engine by the Aid of Photographic Visualization" ASME ICE-Vol.10(Book No.G00505), pp77-85, 1990.
3. WAKURI, Y., TAKASAKI, K., MAEDA, K., YANG, Y., OKUBO, H. and HINO, S. "Studies on Combustion of Residual Fuel Sprays in a Diesel Engine with the Aid of Visualization Method" ASME ICE-Vol.17(Book No.G00648), pp77-84, 1992.

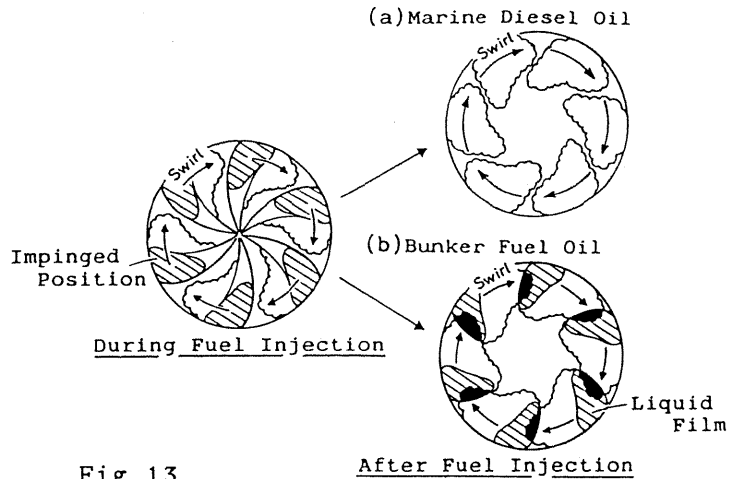
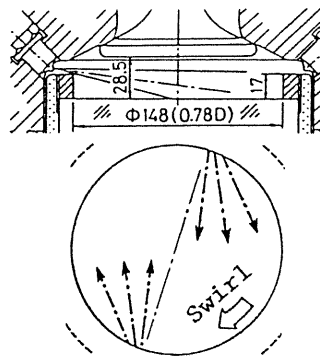
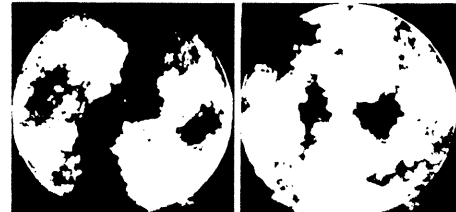

Fig.13 Two models of flame motion under the central-injection system



Swirl Intensity ... $\sin\theta = 0.5$

Fuel ... Marine Diesel Oil



Fuel ... Bunker Fuel Oil



ATDC5° ATDC10°

Fig.14 Flame distribution under the side-injection system (Test engine)