

Combustion and Emissions of Low Heat Rejection Ceramics Methanol ATAC Engine -Surface Temperature Effect on Aldehyde Emission and Heat Transfer-

S.Takase, Y.Enomoto* and N.Iida

*Mechanical Engineering Department
Keio University*

*3-14-1 Hiyoshi, Kouhoku-ku, Yokohama 223
Japan*

** Musashi Institute of Technology*

ABSTRACT

When methanol was used as fuel, hazardous unburned methanol, aldehyde were exhausted. To solve this, low heat rejection engine with ATAC (Active Thermo-Atmosphere Combustion) system was investigated.

The characteristics of combustion process and emissions from ceramics methanol fueled ATAC engine were examined. Widening of ATAC operation region at low BMEP operation condition by use of methanol, and reduction of carbon monoxide emission was persuaded by experiment. By using ceramics for the combustion chamber, the surface temperature of combustion chamber wall was kept at high temperature by 100 to 250 degree. When the temperature of combustion chamber wall became high, the thermal efficiency was reduced because of too early ignition timing in ATAC operation. Supplying a fuel lean mixture to the engine had a good result in both exhaust emissions and fuel consumption.

The relationship between the surface temperature and both formaldehyde emission and instantaneous heat transfer was investigated. The instantaneous heat flux and/or the temperature swing increased with the increment of the time-averaged temperature. Sudden rise of the instantaneous heat flux was observed when the surface temperature was higher than about 700 K. It was expected that the frame quenching layer was destroyed. As a result, at the high surface temperature formaldehyde emission generated in the quenching layer decreased.

INTRODUCTION

Due to the features that two stroke cycle engines are of small size and light weight, and are easy to obtain high power output, those have been used widely as compact engines. However, they have such demerits that they lack stable operation property at low speed and low load, and the emission of unburned hydrocarbon is much at the time of high load due to the suction and exhaust

mechanism. However, it has been reported that according to some conditions of engine speed and internal EGR, there exists the region where smooth operation can be done by the combustion which generates very little unburned hydrocarbon and is very stable in low load. This form of combustion with the little variation of combustion cycle is called Active Thermo-atmosphere Combustion (ATAC) by OHNISHI et al.[1], and it is presumed that its combustion mechanism is multi-point self ignition and bulk state combustion.

In the case of using methanol as fuel, the discharge of formaldehyde and unburned methanol becomes a problem. As its countermeasures, the adoption of ATAC method and further, the heat insulation and the heightening of temperature by changing the combustion chamber wall to ceramics have been proposed[2].

For the purpose of investigating the feasibility of ceramic heat insulation type methanol ATAC engine, this research was to experimentally examine on the effect of heightening the temperature of the combustion chamber wall surface. First, in the case of using methanol and gasoline as fuel, the difference in the operation characteristics and the combustion characteristics at the time of the ATAC operation was compared and examined, and next, in the case of insulating heat and heightening the temperature by changing the combustion chamber wall surface to ceramics, the ignition of methanol, the features of the combustion reaction and the effect to exhaust at the time of the ATAC operation were examined. Further, by forming thin film thermocouples on the cylinder head, the temperature swing on the wall surface was measured, and by the Fourier analysis method, the behaviors of the temperature swing on the wall surface and instantaneous heat flux were investigated, in this way, the relation of the heightening of temperature of the combustion chamber wall with combustion and exhaust and its relation with excessively early ignition or hot surface ignition were examined, therefore, those are reported.

TEST ENGINE AND EQUIPMENT

As the engine for the test, an ATAC process, NiCE-10 type engine (air cooled, two stroke, upright single cylinder, displacement 98 cc, compression ratio 6.0) in Nippon Clean Engine Co. was used. In Fig. 1, the sectional drawings of the engine for the test and the parts changed to ceramics are shown. The throttle in the scavenging port is its feature, and by this means, the ATAC is realized. In this experiment, the material of the cylinder head which is the component of the combustion chamber wall surfaces was changed to a ceramics (silicon nitride), and it was used in addition to the conventional aluminum alloy cylinder head. As the fuel, gasoline and methanol were used, and by using engine speed and BMEP as the parameters, the experiment was carried out. In Fig. 2, the measuring system for this experiment is shown. As for the judgement of the ATAC operation, it was judged by whether the stable operation can be maintained or not after spark ignition was temporarily stopped during the operation of the engine.

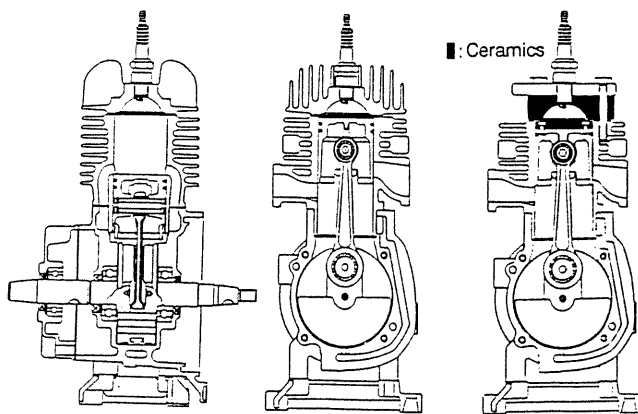

Fig. 1 Section drawings of the engine (aluminum alloy and silicon nitride)

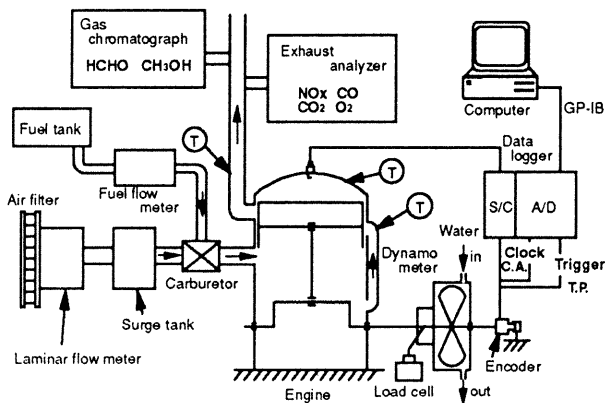

Fig. 2 Measuring system

The measurement of formaldehyde in the exhaust was done by the method of reducing it to methane by Ni catalyst reduction process, thereafter, detecting with FID[3].

The structure of the thin film thermocouple used for measuring the temperature swing on the combustion chamber wall surface is shown in Fig. 3 (for measuring the case of aluminum alloy) and in Fig. 4 (for measuring the case of ceramics). From the temperature swing on the combustion chamber wall surface measured by forming the thin film thermocouples shown in Fig. 4 in the cylinder head made of ceramics at the positions of measurement in Fig. 5, the temperature in the wall and instantaneous heat flux were determined by solving a one-dimensional heat conduction equation by the Fourier analysis method. Regarding the thin film thermocouple for measuring the temperature swing on the ceramics combustion chamber wall surface, in the coaxial thin film thermocouple with the ceramic base material, to which Fig. 3 was applied, since the thermal conductivity of the ceramic material and the adhesive for fixing is small as compared with that of metals, the difference from the true temperature swing becomes large[4]. Accordingly, the wire pair thin film thermocouple, in which lead wires are sufficiently distant from the hot junction as shown in Fig. 4, was adopted.

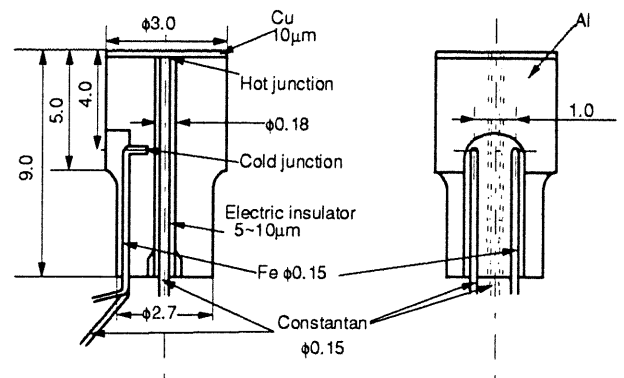

Fig. 3 Coaxial thin film thermocouple for aluminum alloy base material

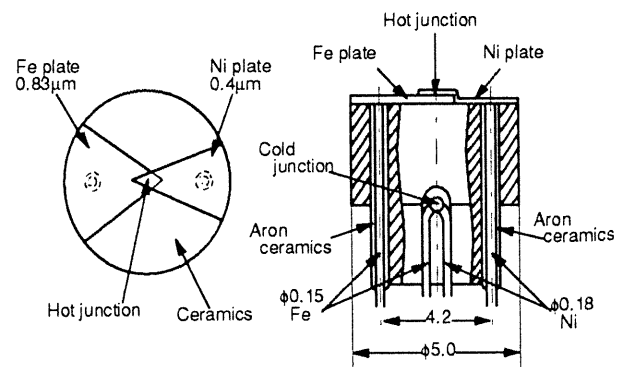

Fig. 4 Wire pair thin film thermocouple for ceramic base material

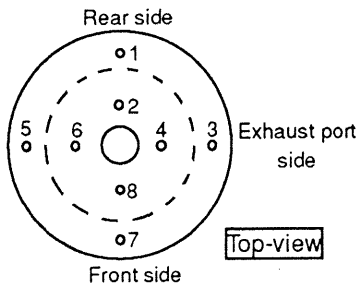

Fig. 5 Positions of measuring temperature on cylinder head (8 points)

RESULTS AND DISCUSSION

Effect to the region of ATAC operation, combustion process and exhaust characteristics due to different fuels

In Fig. 6 and Fig. 7, the region of the ATAC operation in the case of using gasoline and methanol as fuels, respectively, is shown by using BMEP and engine speed as the parameters.

When methanol was used as the fuel, the region of the ATAC operation was largely extended as compared with the case of using gasoline. Particularly the extension to the region of low engine speed and to the region of low BMEP was observed, and the idle operation at no load becomes feasible in the range from 2000 rpm to 3500 rpm by the ATAC. Besides, whereas the region with \blacktriangle marks in the graph, namely the region where the ATAC and conventional combustion arose in mixed state, existed frequently in the case of using gasoline, in the case of using methanol, there was such feature that the regions of the ATAC and conventional combustion were clearly distinguished.

In Fig. 8, when gasoline and methanol were used as fuels, the indicator diagrams and the comb-like diagrams for continuous 50 cycles at engine speed of 3500 rpm and BMEP of 0.05 MPa are shown. In the case of the same BMEP, the highest pressure in the cylinder was higher when methanol was used. Under this condition, in the case of using gasoline, the operation became conventional combustion operation, and in the case of using methanol, the operation became the ATAC operation. In the ATAC, the rapid pressure rise after ignition that is seen at the time of conventional combustion was not observed, and pressure rose slowly. Moreover in the region of the ATAC operation, the variation of indicator diagrams in cycles was very little. This was particularly conspicuous when methanol was used as fuel, and the stable combustion, in which the variation in the process of rate of heat release in every cycle is very small, was realized.

As for respective cases of using gasoline and methanol as fuels, the example of the analysis of the process of rate of heat release at rotation speed of 3500 rpm and BMEP of 0.05 MPa, which are the region of the ATAC operation in both cases, is shown in Fig. 9. Besides, the ignition timing (the time of beginning heat generation) determined by the analysis of the process of

rate of heat release and the characteristic time of combustion are shown in Fig. 10. t_i , t_{50} , t_{90} and t_{100} in the figure shown the time of ignition and the time when combustion advanced by 50%, 90% and 100%. When comparison was made at the same BMEP, in methanol, the octane number is high and the cetane number is low as compared with gasoline, notwithstanding, its time of ignition is early, and the combustion duration is short. Besides, maximum rate of heat release is larger in methanol, and the combustion advances rapidly. The timing of spark ignition in this engine is 21° BTDC, but according to Fig. 10, in the case of using methanol, it was judged that the time of ignition was about 20° BTDC, and it was able to be confirmed that it was clearly the operation by self ignition.

In Fig. 11, as for respective cases of using gasoline and methanol as fuels, the volume concentrations of carbon monoxide and nitrogen oxides in exhaust when BMEP was changed under the condition of constant engine speed at 3500 rpm, which is the region of the ATAC operation in both cases, are shown. The discharge of carbon monoxide which is an unburned composition decreased remarkably in the case of using methanol. Nitrogen oxides tended to increase in the case of using methanol, but this seems because, due to the occurrence of early ignition, the mean temperature of the gas in the combustion chamber during cycles was high, and for this reason, nitrogen oxides increased.

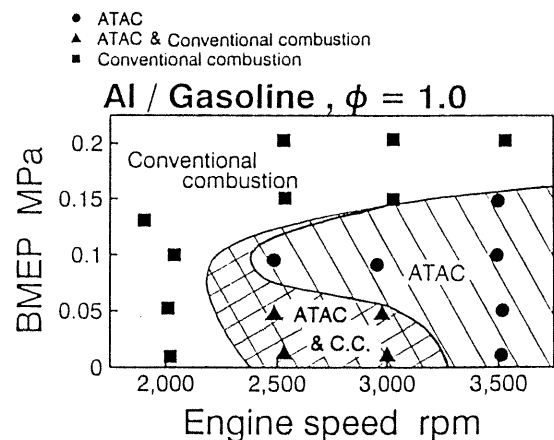

Fig. 6 Region of ATAC operation of the engine (case of using gasoline)

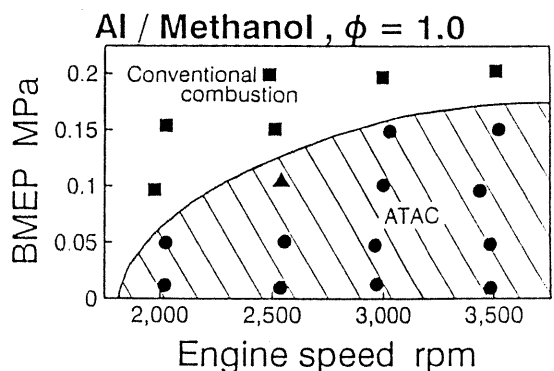

Fig. 7 Region of ATAC operation (case of using methanol)

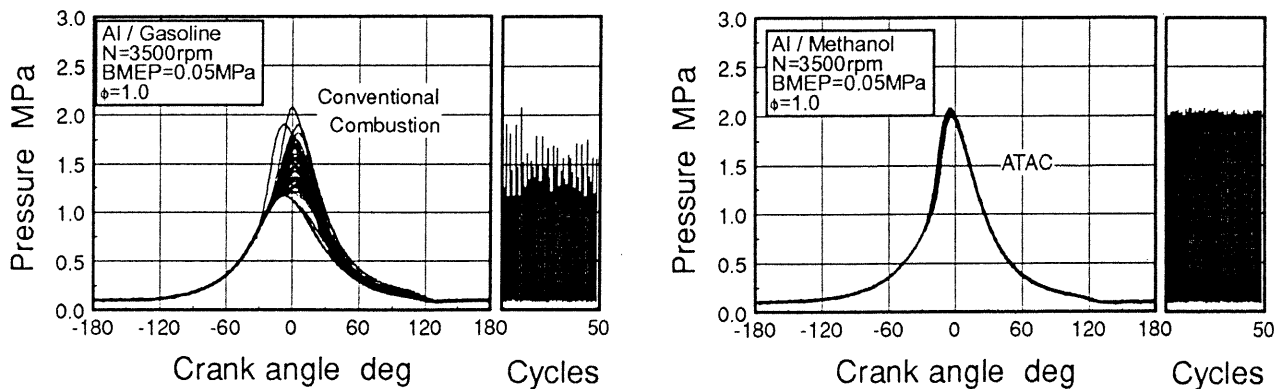

Fig. 8 Comparison of cycle variation of indicator diagrams at the time of conventional combustion and ATAC operations (continuous 50 cycles)

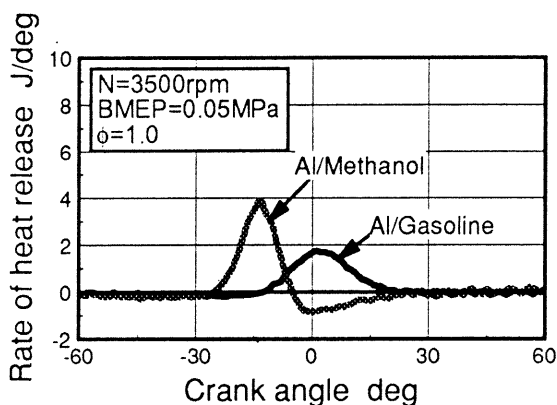

Fig. 9 Process of rate of heat release at the time of ATAC operation (Comparison of methanol and gasoline)

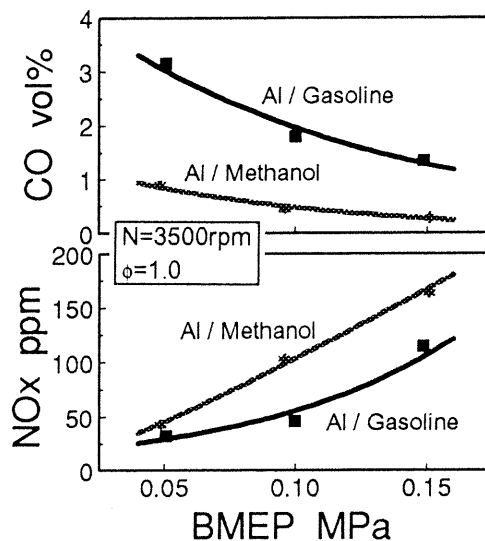

Fig. 11 Concentrations of carbon monoxide and nitrogen oxides in exhaust (Comparison of gasoline and methanol)

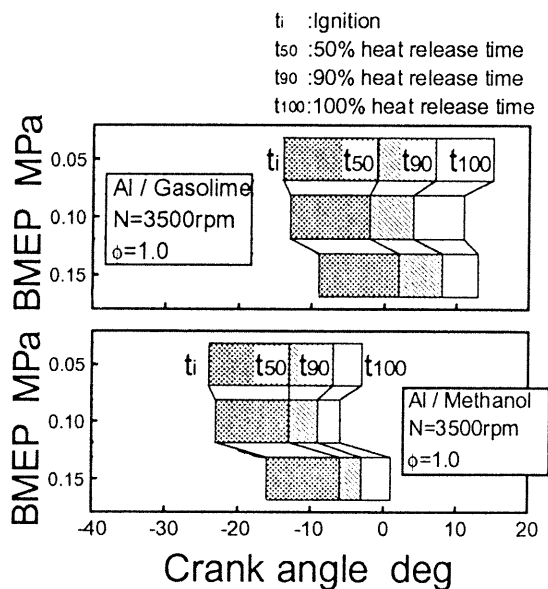

Fig. 10 Time of ignition timing and combustion duration at the time of ATAC operation (Comparison of gasoline and methanol)

Effect of heightening temperature of combustion chamber wall surface by heat insulation

The region of the ATAC operation when silicon nitride was used as the material of the cylinder head is

shown in Fig. 12. When the temperature of the combustion chamber wall was heightened, the region of the ATAC operation extended particularly in the region of low engine speed. Besides, at the BMEP exceeding about 0.20 MPa when methanol was used, after start-up, pre-ignition arose with the temperature rise on the combustion chamber wall surface, and steady operation was not able to be obtained, therefore, the experiment was carried out by raising the heat value of the spark plug.

In Fig. 13, the temperature of the combustion chamber wall surface at the point of measurement 2, measured by using engine speed and BMEP as the parameters, is shown. When engine speed and BMEP became high, also the temperature of the wall surface rose, but the region of the ATAC operation was not able to be specific by the range of some specific wall surface temperature.

In Fig. 14, the temperature measured at eight points on the combustion chamber wall surface at the time of the ATAC operation at engine speed of 3500 rpm and BMEP of 0.05 MPa is shown. The points of measurement 1, 3, 5 and 7 were in the squish area, and

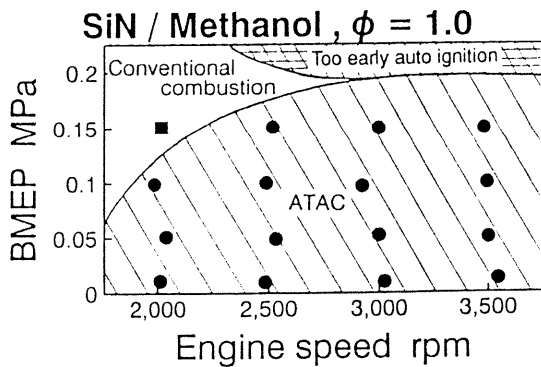

Fig. 12 Region of ATAC operation in the LHR ATAC engine (methanol)

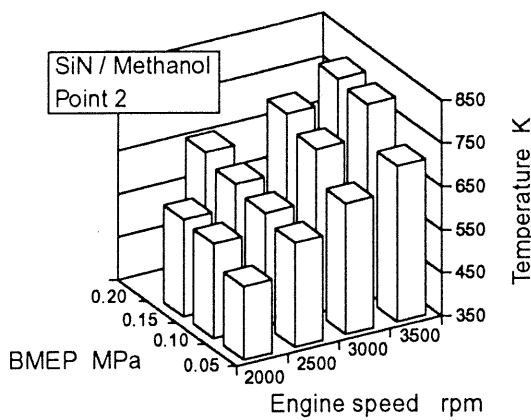

Fig. 13 Relation of temperature of combustion chamber wall surface with engine speed and BMEP

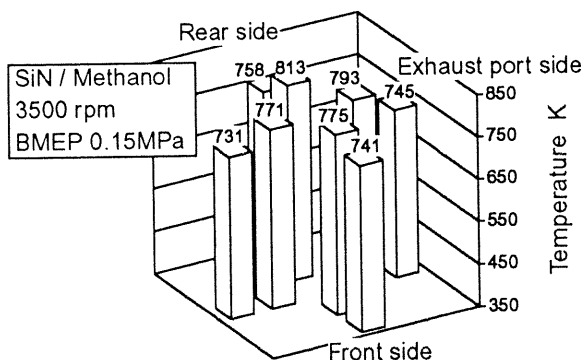

Fig. 14 Temperature at 8 points on cylinder head

flame was hard to reach there, therefore, the temperature on the wall surface became lower than the central side of points 2, 4, 6 and 8.

The state of swing of the temperature of the combustion chamber wall surface T_{wall} which was the average of 256 cycles at the point of measurement 2 at engine speed of 3500 rpm and BMEP of 0.15 MPa is shown in Fig. 15. All are in the region of the ATAC operation. In the case of methanol fuel, the time-averaged wall surface temperature T_{wall} has risen by

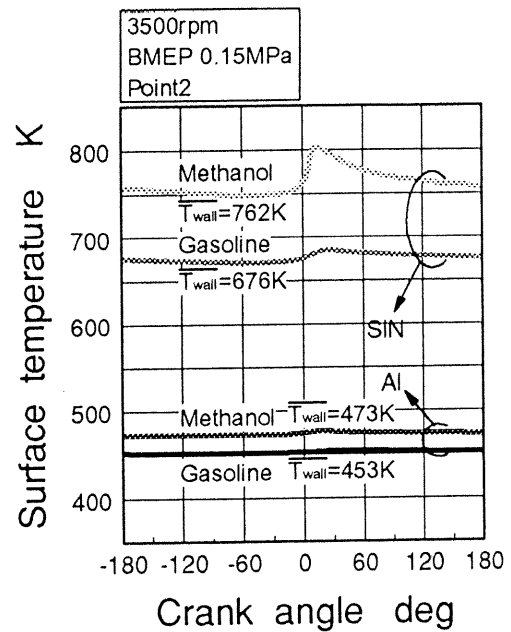

Fig. 15 Temperature swing at point 2 on combustion chamber wall surface at engine speed of 3500 rpm and BMEP of 0.15 MPa (Comparison of LHR engine and aluminum cooling type engine, the ensemble average of 256 cycles)

about 20K in aluminum alloy and by about 80K in silicon nitride. When the change to the ceramics was carried out, the time-averaged wall surface temperature T_{wall} has risen by about 200K in the case of using gasoline, and by about 300K in the case of using methanol. Besides, it is known that the temperature swing ($\Delta T_{wall} = T_{Wmax} - T_{Wmin}$) increased also at the time of using methanol, but the increase of the temperature swing due to the change to the ceramics was more conspicuous.

Moreover, for the measurement of the wall surface temperature, in Fig. 13 and Fig. 14, the iron-constantan thermocouples, of which the hot junctions were formed with silver solder, were used, and the temperature value at the hot junction which became constant was adopted as the wall surface temperature. But in Fig. 15, thin film thermocouples were used, and the temperature at the hot junction when the temperature at the cold junction which was formed several millimeter inside the wall from the hot junction became constant was taken as the measured value. Consequently, the time-averaged wall surface temperature in Fig. 15 and the wall surface temperature in Fig. 13 and Fig. 14 did not agree, and the wall surface temperature measured with iron-constantan thermocouples became higher than the time-averaged wall surface temperature measured with thin film thermocouples.

The temperature distribution in the wall determined by the Fourier analysis from Fig. 15 is shown in Fig. 16. It is known that the temperature gradient in the wall of silicon nitride became steeper than that of aluminum alloy. When temperature boundary layer was defined by the region in which the amplitude becomes 1% of the

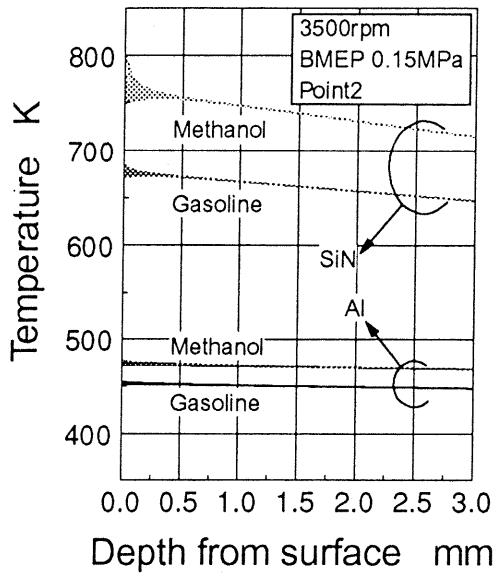

Fig. 16 Temperature distribution in the wall determined by Fourier analysis

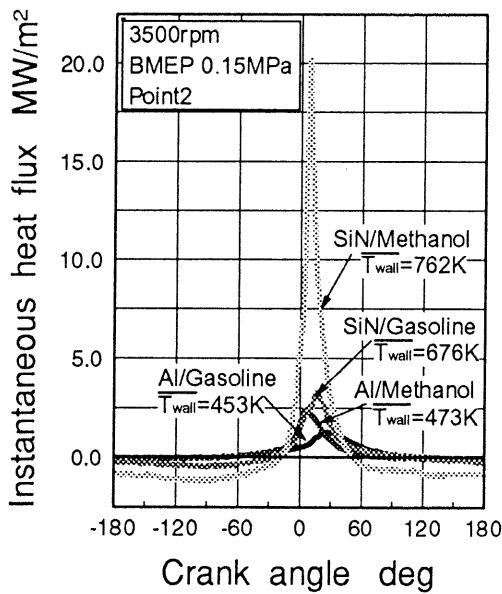

Fig. 17 Effect that time-averaged wall surface temperature exerted to instantaneous heat flux process

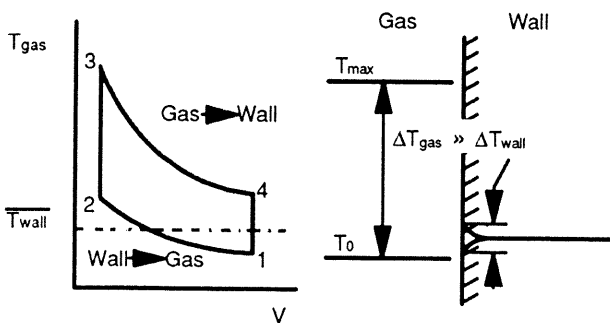

Fig. 18 T-V diagram model

temperature swing on the surface, in the case of silicon nitride, whereas it was about 0.7 mm, in the case of aluminum alloy, it became about 2 mm.

Figure 17 shows instantaneous heat flux when the Fourier analysis was applied to Fig. 15. It was able to be confirmed that instantaneous heat flux increased independent of the wall materials in methanol combustion. Also in the case of changing to the ceramics, instantaneous heat flux increased. Moreover in the case of methanol combustion, the time of maximum instantaneous heat flux became early, and the period in which heat flux flowed in the combustion chamber wall became short.

Explaining by referring to the T-V diagram in Fig. 18, as the result of the rise of time-averaged wall surface temperature T_{wall} , the period in which heat flowed from the wall surface side to gas side in one cycle became long, and this is the reason. Generally, the swing of wall surface temperature ΔT_{wall} is far small as compared with the swing of gas temperature in the combustion chamber ΔT_{gas} , therefore, it was regarded as constant. Besides, as shown in Fig. 10 mentioned before, it is known from the fact that the timing of ignition became early, and the combustion duration became short at the time of using methanol fuel, that the period in which instantaneous heat flux was positive in Fig. 17, namely the period in which heat flowed from gas side into the wall surface side, became short.

In order to examine the correlation of time-averaged wall surface temperature T_{wall} with the temperature swing ΔT_{wall} , in Fig. 19, the measured data at the points of measurement 2 and 7 were plotted. It was observed that at the time-averaged wall surface temperature below or above 620K, it took the different behavior. Namely, it is known that in the temperature range below about 600K, the swing ΔT_{wall} of the wall surface temperature T_{wall} increased nearly in proportion accompanying the rise of the wall surface temperature T_{wall} , if the engine speed is same. Explaining by referring to Fig. 20, in the behavior of working gas in the case of the temperature of the combustion chamber wall surface being low or high, when it was low, the mean temperature of working gas due to compression and combustion and the temperature of working gas near the wall seemed to be about the same degree. But when the wall surface temperature was high, since the temperature distribution of working gas in the temperature boundary layer before compression took the steep gradient, the highest temperature of working gas after compression arose inside the temperature boundary layer, and the swing ΔT_{wall} of the wall surface temperature T_{wall} increased.

Moreover, when time-averaged wall surface temperature exceeded 650K, the swing of wall surface temperature has rapidly increased. When λ represents thermal conductivity, ρ density and c specific heat, $\sqrt{\lambda \rho c}$ is called thermal effusivity, and it has been known that if it is assumed that the same heat quantity flows in one

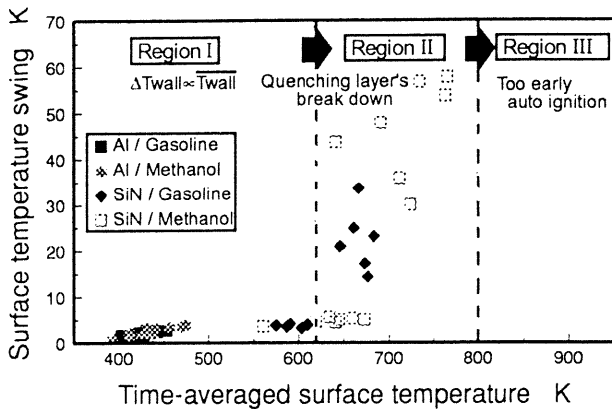

Fig. 19 Relation of time-averaged wall surface temperature T_{wall} with the temperature swing ΔT_{wall}

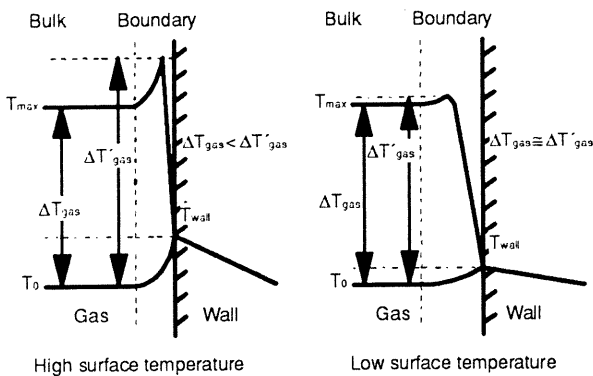

Fig. 20 Effect that the temperature rise of wall surface exerted to temperature distribution of working gas in temperature boundary layer

cycle at same engine speed the temperature swing is proportional to $1/\sqrt{\lambda pc}$ [5]. Since $1/\sqrt{\lambda pc}$ is a function of temperature, time-averaged wall surface temperature and the temperature swing should be proportional. However according to Fig. 19, it is considered that the temperature swing is dependent not only on the change in the thermal properties of silicon nitride but also on the change in combustion reaction form in the temperature boundary layer near the wall accompanying the temperature rise on the wall surface. When the temperature was raised on the wall surface, the distance of flame quenching layer was broken down, and the region of the reaction of flame zone, namely the region where much intermediate products of the reaction were present, approached the wall surface. As the result, it is considered that the temperature swing increased.

Moreover, as other factors, the effect of the deposit adhered to the wall surface is conceivable. A case has been reported that on the combustion chamber wall surface of high temperature, the porous deposit which becomes a thermal resistance is hard to be formed, therefore, heat flux increased as compared with low temperature wall surface[5]. In this research, there was the possibility that in the case of using methanol as fuel, the castor oil which was mixed as the lubricant adhered to the combustion chamber wall surface and formed thin

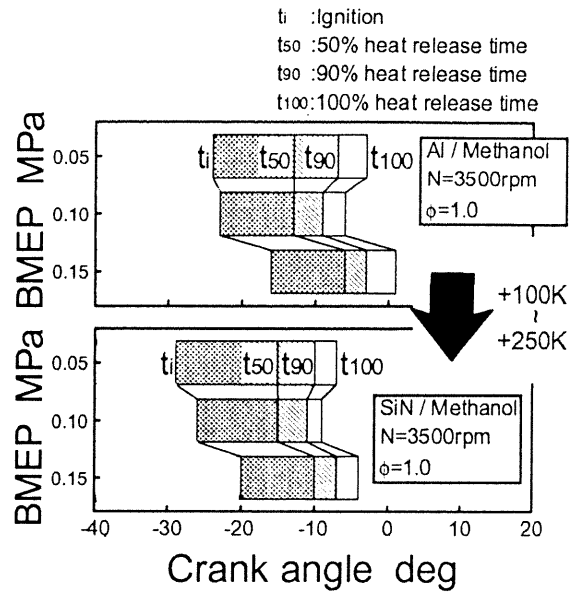

Fig. 21 Effect that high temperature of wall surface exerted to ignition timing and combustion duration

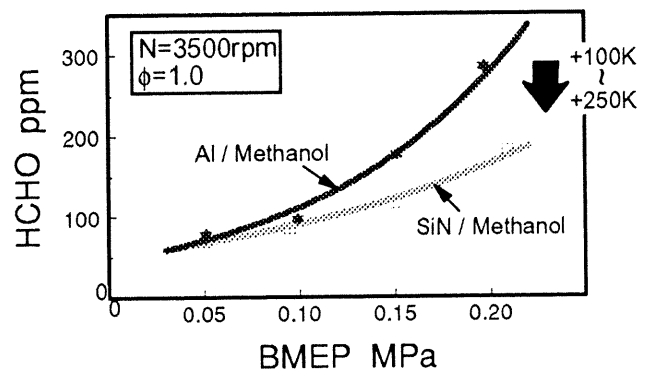

Fig. 22 Concentration of formaldehyde in exhaust and effect of heightening temperature of wall surface

films in the extremely low load region after the low temperature start-up.

In Fig. 21, the timing of ignition and the combustion duration in case operation was carried out by maintaining scavenging temperature nearly same at engine speed of 3500 rpm are shown. By the temperature rise of the combustion chamber wall surface, the timing of ignition became early, but the combustion duration hardly changed. As the reason of the timing of ignition becoming early, it is considered that by the temperature rise of working gas in the temperature boundary layer (high temperature heat atmosphere) which was brought about by the heat insulation at the combustion chamber wall surface, the time of attaining ignition was shortened. As the countermeasure, the method of delaying ignition to the proper timing by lean mixture is conceivable, however, there is the limit in lean mixture, and in the case of this engine, it has been known that even by diluting to the equivalence ratio of around $\phi = 0.80$, the stable combustion of the ATAC

method is possible, and the improvement of fuel consumption and the reduction of NO_x and CO emission can be obtained. Excessive lean mixture ($\phi = 0.7$) causes the extension of combustion duration[6].

In Fig. 22, when the aluminum alloy and the ceramics were used as the cylinder head, the results of the analysis of formaldehyde in exhaust in case scavenging temperature was about same at respective BMEP and at engine speed of 3500 rpm are shown. By heightening the temperature of the combustion chamber wall surface, the discharge of formaldehyde decreased in the whole range of loading. By heightening the temperature of the combustion chamber wall surface, the flame quenching distance became short, consequently, heat flux has increased, but the generation of formaldehyde in the flame quenching layer on the combustion chamber wall surface was able to be decreased.

CONCLUSION

- (1) When methanol was used, the region of the ATAC operation represented by engine speed and BMEP extended largely as compared with the case of using gasoline. In particular, the effect of the extension to low load region was conspicuous, and in high speed idling, the self ignition operation by the ATAC is feasible.
- (2) By the ATAC operation using methanol fuel, the stable combustion with very small variation in the cycles of indicator diagrams in the cylinder was obtained, besides, it was effective for reducing carbon monoxide which is an unburned gas composition in exhaust.
- (3) In the case of using methanol as fuel, notwithstanding the cetane number is low and the octane number is high, the time of self ignition in the ATAC (the time of beginning heat generation) was early as compared with the case of using gasoline. When comparison was made at the same equivalence ratio, regardless of the materials of the combustion chamber wall, the time-averaged wall surface temperature, the temperature swing and instantaneous heat flux increased.
- (4) When the time-averaged wall surface temperature was heightened by the heat insulation structure using the ceramics, both temperature swing and instantaneous heat flux increased. This is independent of the kinds of fuel. As for the cases of using both aluminum and ceramics, the temperature swing tended to increase in proportion to the rise of the time-averaged wall surface temperature.
- (5) When the time-averaged wall surface temperature was heightened extremely and exceeded 650K, the temperature swing on the wall surface increased rapidly. This is considered because the temperature boundary layer became extremely thin due to the collapse of the flame quenching layer of premixed gas flame

accompanying the heightening of temperature on the wall surface.

- (6) By heightening the temperature of the combustion chamber wall surface, the discharge of formaldehyde in exhaust decreased in the whole region of operation. It is considered to be caused by having reduced the formaldehyde which arose in the flame quenching layer at the wall surface boundary.

ACKNOWLEDGEMENT

A part of this research was carried out as the research project of No. 2 Laboratory, Kanagawa Academy of Science and Technology (KAST). The engine for the test was offered by Mr. Shigeru OHNISHI of Nippon Clean Engine Co.. Moreover, at the time of the analysis of the ATAC combustion of methanol, guidance was given by Mr. Osamu HIRAO of Mukuta Inst.. At the time of the experiment, FUKUTANI and FUJIWARA researchers and HOSONUMA, YOSHIMURA, OHKI and TANAKA assistants cooperated. The authors express there hearty gratitude to all of these people.

REFERENCES

1. Ohnishi, S., Jo, S.H., Shoda, K., Jo, P.D. and Kato, S., "Active Thermo-Atmosphere Combustion Process for Internal Combustion Engines," SAE Paper No. 790501, 1979.
2. Iida, N., "Possibility of High Temperature Combustion Using Methanol in Ceramic LHR Engine," Iida "Ceramic Two-Stroke-Methanol Engine" Project research paper, Kanagawa Academy of Science and Technology (KAST), pp. 1-20, 1993.
3. Kachi, H., Akiyama, K., Nakano, N. and Igarashi, N., "Development of Automatic Analyzer for Methanol and Formaldehyde," JSAE Autumn Convention Proc. 892 (in Japanese), pp. 49-52, 1989.
4. Enomoto, Y., Haresawa, H., Kimura, S. and Fujiwara, T., "Measurement of Heat Loss on the Ceramic Combustion Chamber Wall," Trans. of the 69th JSME Fall Annual Meeting (in Japanese), Vol. B, pp. 678-680, 1991.
5. Boggs, D.L. and Borman, G.L., "Calculation of Heat Flux Integral Length Scales from Spatially-Resolved Surface Temperature Measurements in an Engine," SAE Paper No. 910721, 1991.
6. Iida, N., Hosonuma, S., Yoshimura, K., Takase, S. and Fujiwara, Y., "Combustion and Emission of Low Heat Rejection, Ceramic Methanol ATAC Engine," Trans. Jpn. Soc. Mech. Eng. (in Japanese), Vol 59, No. 568, B, pp. 330-337, 1993.