

# Comparison of Simulation and Experimental Results in Cylinder Air Motion

T. Adachi

*1st Light-Duty Engine Engineering  
Isuzu Motors Ltd.  
8 Tsuchidana, Fujisawa 252  
Japan*

C.M. Shu

*Isuzu Ceramics Research Institute*

## ABSTRACT

In this study, calculation was carried out by taking the values measured at BTDC90° with LDV (Laser Doppler Velocimeter) for the two cases of low and high swirl as initial values. The accuracy of the simulation was checked by comparing the values calculated for the subsequent crank angles with the corresponding experimental values.

The results of this study revealed that in the case of low swirl, the flow field could be simulated with high degree of accuracy by taking the experimental values as initial conditions and selecting the parameters of turbulence appropriately.

However, in the case of high swirl, simulation could not be carried out properly even by taking, as initial conditions, the experimental values. In this study the KIVA[1] code was used for the simulation.

## INTRODUCTION

Predicting air motion in the cylinder and in the combustion chamber is very important for improving combustion in internal combustion engines, specially in direct injection diesel engines.

During the last few years many numerical simulation studies have been carried out on the air motion in the cylinder using multidimensional model prepared on the basis of computational fluid dynamics.

Unfortunately, most of these simulation studies did not seem to have paid much attention to accuracy, by strictly taking the experimental values as initial conditions for the velocity, and comparing the calculated results with the experimental ones [2,3]. In most of these studies, simulation has been carried out by assuming some arbitrary velocity distribution as initial conditions. For, the case of the cylinder, where the air motion is highly unsteady, it can be easily imagined that any variation the assumed initial conditions will have a great effect on the flow field. Such a situation is undesirable when high accuracy of simulation is to be achieved.

In this study, simulation was first carried out by using measured values at BTDC90° with LDV as initial conditions for both low and high swirl. The experimental and simulation results were compared.

Then, the same simulation was carried out this time with assumed initial conditions. Again, the simulation results were compared with the experimental results.

## NUMERICAL SIMULATION

### Calculation Method

The simulation method followed in this study was based on the KIVA code developed at the Los Alamos Laboratory. The initial velocity distribution was set in the form of forced vortex over the whole zone, and the axial distribution of the velocity near the piston face was initialized to the piston speed. The axial velocity distribution away from the piston face was set to zero. These are the only preset initial conditions in the KIVA code.

In this study, the method employed by Fujii et al[3] was adopted so that calculation could be carried out under arbitrary initial conditions. In short, the radial velocity, that would satisfy the mass conservation law, was calculated by setting arbitrary tangential and axial velocity. These three components of the velocity were used as the initial values in the calculation.

The following governing equations were used.

$$\frac{\partial \rho}{\partial t} + \nabla \cdot (\rho U) = 0 \quad (1)$$

$$\frac{\partial (\rho U)}{\partial t} + \nabla \cdot (\rho U U) = -\nabla P + \nabla \cdot \sigma \quad (2)$$

These equations were discretized by finite difference method, and solved by the ALE (Arbitrary -Lagrangian- Eulerian) method that can treat moving boundary. Wall function was used as the wall boundary condition.

Subgrid scale model was used in treating the turbulent flow. The turbulent kinetic energy was calculated by solving its transport equation. The turbulent viscosity was estimated by putting the turbulent kinetic energy and the characteristic length

was determined algebraically. these equations are shown below.

$$\partial(\rho q) + \nabla \cdot (\rho q U) = -\frac{2}{3} \rho q \nabla \cdot U + \sigma : \nabla U + \nabla \cdot (U \nabla q) - D \rho L^{-1} \dot{q}^{1/2} \quad (3)$$

$$\mu_t = A \rho L q^{1/2} \quad (4)$$

Combustion Chamber Model

The shape of the combustion chamber was similar to that of the engine used in the experiment. It had a flat piston and a flat cylinder head face. Table 1 shows the specifications of the engine used in the simulation and in the experiment.

The grid used in the simulation had 16X27 points at BTDC90° in the radial and the axial directions respectively.

Table 1 Specification of transparent engine

Cycle	4-stroke
Bore-Stroke	80(mm)-80(mm)
Displacement	402(cc)
Compression ratio	4.81
Connecting rod length	200(mm)
Minimum clearance height	21(mm)
Engine speed	320(rpm)
Swirl ratio	1.5, 3.6

Initial Conditions

The calculation in this study covered the range from BTDC90° to ATDC90°. Consequently the velocity at BTDC90° was taken as the initial condition. Table 2 shows the initial and the calculation conditions used in this study.

First, the accuracy of the simulation was checked. This is done by setting the actual values measured with LDV at BTDC90° to the initial conditions. This was done for both the low and the high swirl.

Next, the simulation was carried out for the case of lower swirl by setting arbitrary velocity distribution.

The parameter length is represented by L in Table 2 and in equation(3), and is used as a calculation parameter by varying its value from L-short to L-long. L-long is 5 times larger than L-short (table 2).

The tangential forced vortex velocity is expressed by  $V_t = r \omega$  (where  $\omega$  is constant). The angular velocity  $\omega$  was set carefully in a way that it equals the swirl ratio at which the experiment was carried out.

Similarly, the axial velocity has been assumed to vary linearly between the piston face and the cylinder head.

LDV MEASUREMENT

Fig.1 shows the apparatus used in the experiment. The engine used here had a transparent quartz glass cylinder with a centered single valve to produce symmetrical axial flow. The swirl ratio was varied by changing the pitch and the aperture of the swirler.

Measurements were carried out with LDV by keeping the engine in motoring condition. The engine speed was 320rpm. Silicon oil of about 4µm in particle diameter was

used for seeding. The flow velocities in the tangential and axial directions were measured. A tracker and a counter were used simultaneously for treating the signals. When they both agreed with each other, the tracker output was taken for calculation.

Fig.2 shows the points inside the cylinder where LDV measurements were carried out. Fig.3 and 4 show some of the measured values at BTDC90° for the low and high swirl respectively.

Table 2 Initial and calculation conditions

Calc. case No.	Characteristic length	Swirl ratio	Tangential velocity	Axial velocity
Case 1	Short	1.5	* M.V.	M.V.
Case 2	Long	1.5	M.V.	M.V.
Case 3	Short	3.6	M.V.	M.V.
Case 4	Long	3.6	M.V.	M.V.
Case 5	Long	1.5	Forced vortex	M.V.
Case 6	Long	1.5	Forced vortex	linear piston speed

\* M.V.: Measurement Values

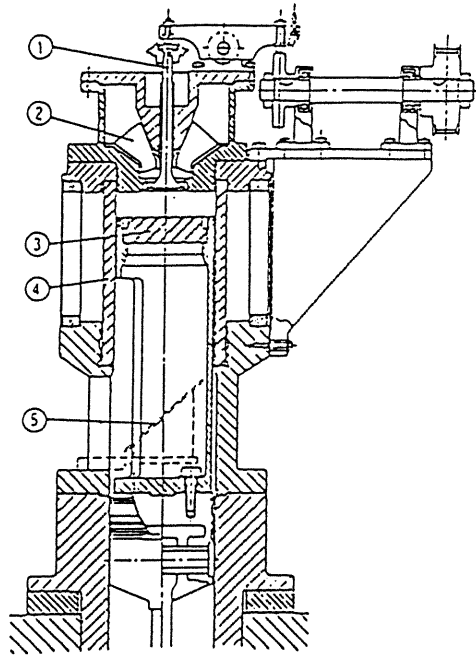

Fig.1 Sectional view of transparent engine

- ① Centered single valve
- ② Swirler
- ③ Quartz piston top
- ④ Quartz liner
- ⑤ Mirror

RESULTS AND STUDY

Case of Low Swirl, with the Measured Values in the Tangential and Axial Directions Taken as the Initial Conditions.

Fig.5 and 6 show the comparison of calculation results for Case 1 and Case 2 of table 2 with the measured values. In these figures, "R" represents the radius

and "Z" the distance from the cylinder head. The negative crank angle denotes the compression stroke, and the positive crank angle denotes the expansion stroke. The axial velocity is taken positive in the upward direction.

From the comparison of axial velocity data, shown in Fig.5, it can be said that the measured values were simulated with a fair degree of accuracy in both cases. However, the result of simulation for tangential velocity given in Fig.6 shows that at ATDC90°, the velocity was low around the center of the axis but high near the cylinder wall for both the experiment and case 2. This shows that the accuracy of simulation was not very good. The reason for this poor simulation accuracy can be attributed to the large value of the length taken in this case. Equations (3) and (4) clearly show that the characteristic length affects both the turbulent kinetic energy and the turbulent viscosity; the accuracy of simulation deteriorated in Case 1 probably because the spatial distribution of these two could not be simulated properly. This finding tends to show that the values of the various parameters of turbulence estimated have there influence on the mean flow, thus affecting the accuracy of simulation.

Fig.7 shows the results of simulation for Case 2 with the help of velocity vector. From this figure it will be seen that as the piston ascended, a pair of vortices appeared and gradually developed into big longitudinal ones around the TDC. As the piston descended, the air was pulled downward, and with this, the vortices expanded and finally disintegrated.

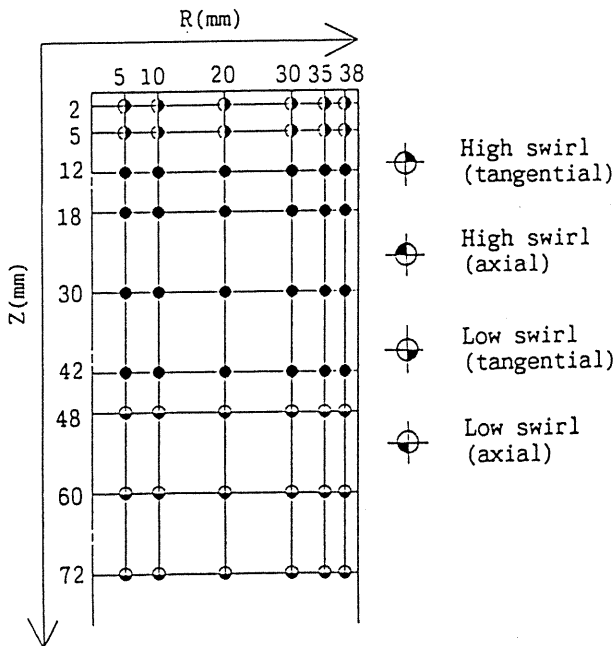

Fig.2 Measurement points by LDV

Reference vector : | 1m/s

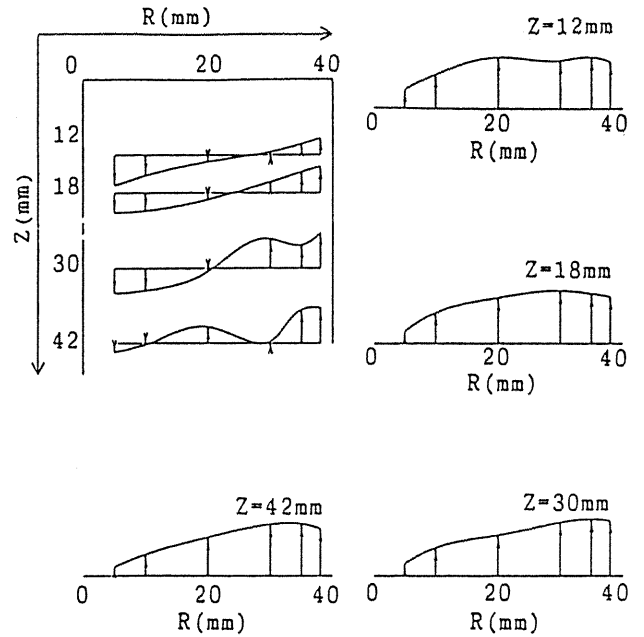

Fig.3 LDV measurement results at BTDC90° (case of low swirl)

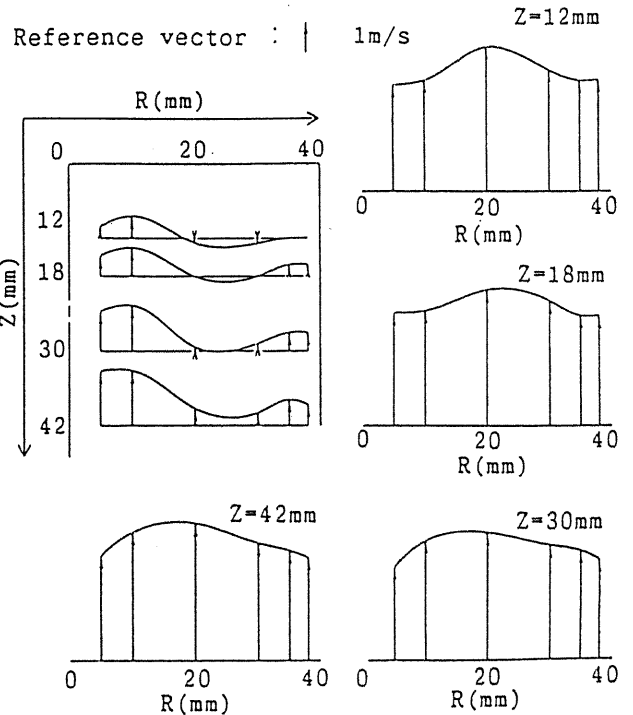

Fig.4 LDV measurement results at BTDC90° (case of high swirl)

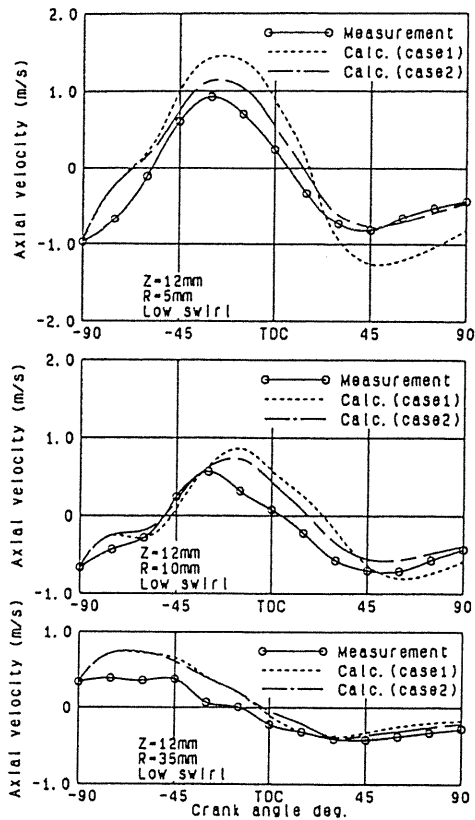

Fig.5 Comparison between measured and calculated axial velocity (case1 & case2)

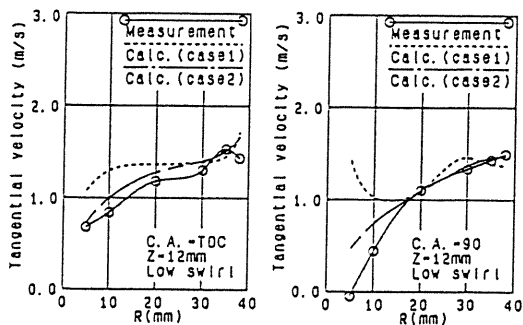

Fig.6 Comparison between measured and calculated tangential velocity (case1 & case2)

Case of High Swirl, with the Measured Values in the Tangential and Axial Directions Taken as Initial Conditions.

Fig.8 and 11 show the comparison of calculation results for case 3 and case 4 of table 2 with the measured values. These figures show that the experimental results were not simulated properly in these two cases. The following can be given as reasons for this failure:

- 1) The turbulent kinetic energy values, used here as the initial values, were the same as those used in the case of low swirl.
- 2) Errors were committed in estimating the velocities at grid points from the measured values.

3) The ability to resolve the grid was not very accurate.

4) Problems involving the turbulence model itself, etc.

These topics will be subjected to further study in the future.

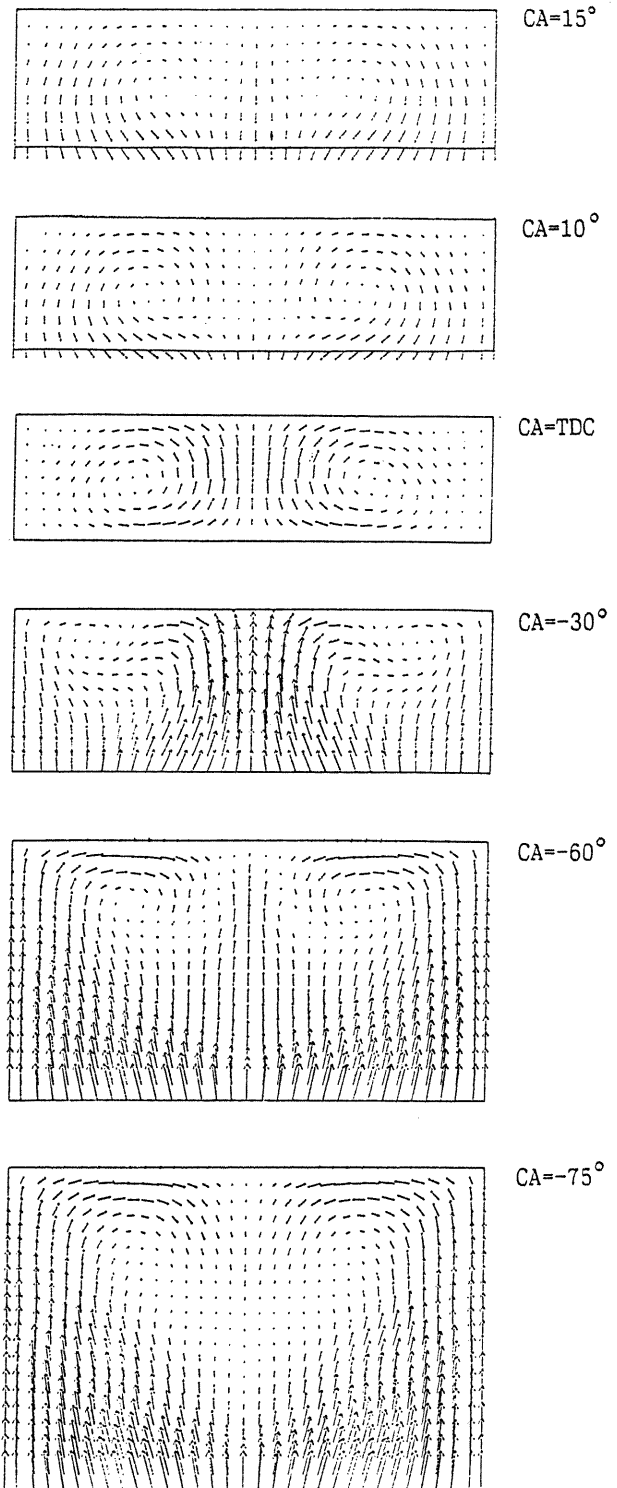

Fig.7 Calculated velocity vector plot for case2

Case of Low Swirl, with Forced Vortex in the Tangential Direction and Measured Values in the Axial Direction Taken as Initial Conditions.

Fig.9 and 10 show the results of simulation carried out for case 5 by assuming forced vortex in the tangential direction and measured values in the axial direction together with the measured values and the simulation results of case 2. These figures show that the simulation accuracy was good even though forced vortex was assumed in the tangential direction. This suggests that the measured values are close to forced vortices in the case of low swirl, and consequently not much discrepancy should appear even if such assumption for forced vortex was made. However, the extent by which the tangential velocity distribution should deviate from forced vortex, adversely affecting the simulation accuracy, could not be deduced from the results of this study.

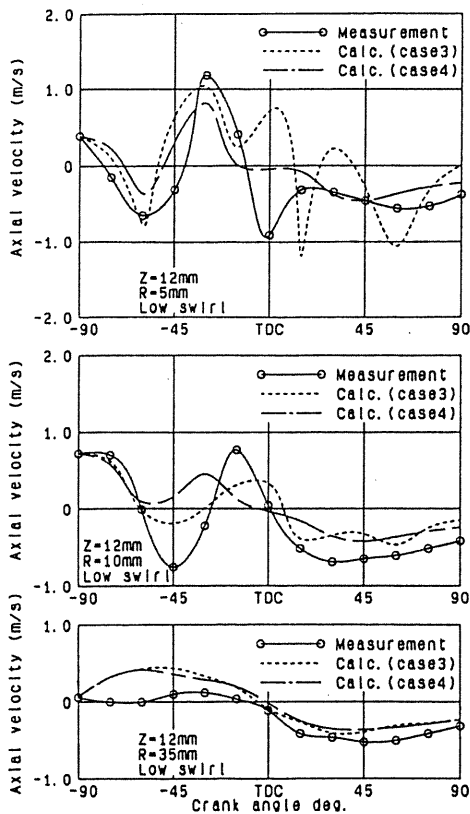

Fig.8 Comparison between measured and calculated axial velocity (case3 & case4)

Case of Low Swirl, with Forced Vortex in the Tangential Direction and the Velocity Distribution, Given by Linear Piston Speed Equation in the Axial Direction, Taken as the Initial Conditions.

Fig.12 and 13 show the results of simulation carried out for case 6 by assuming forced vortex in the tangential direction and the velocity distribution given by the linear piston speed equation in the axial direction, together with the experimental values and the simulation results of case 5.

According to Fig.12, the axial velocity in case 6 maintained more or less the same value for the same crank angle independently of the radial position. In contrast, in the cases of measured values and case 5, the velocity was downward near the center and upward near the wall up to BTDC 60°, showing the existence of vertical vortex. No such vortex could be detected in case 6. A study of tangential velocity for case 6 in Fig.13 shows that both the TDC and ATDC90° have more or less the same velocity distribution, and that this distribution is not substantially different from that of the forced vortex used as the initial value. In other words, the forced vortex assumed at the start of simulation survived unaffected after the simulation. This shows that the simulation with good accuracy is not possible under the initial conditions defined in case 6.

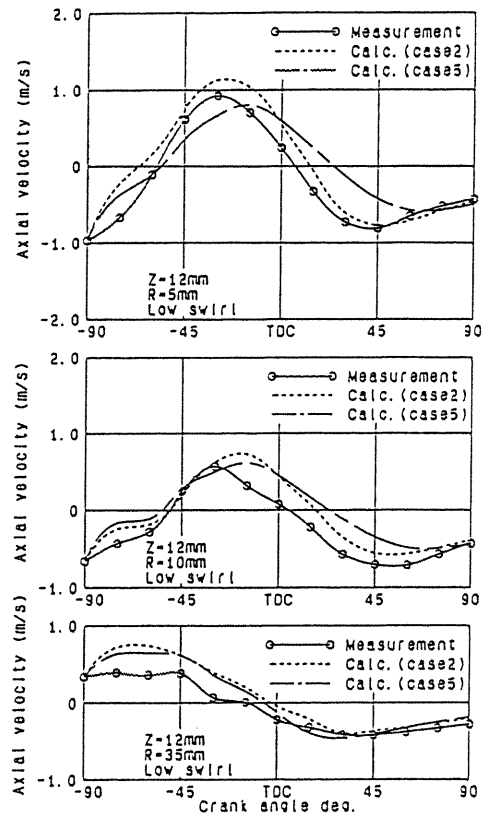

Fig.9 Comparison between measured and calculated axial velocity (case2 & case5)

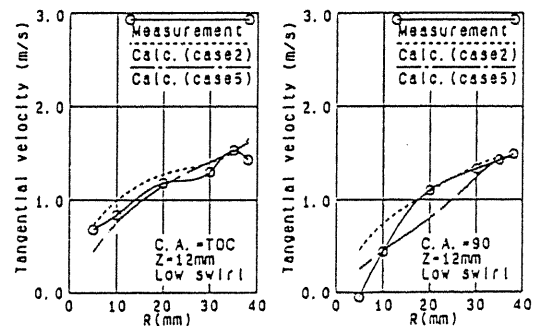

Fig.10 Comparison between measured and calculated tangential velocity (case2 & case5)

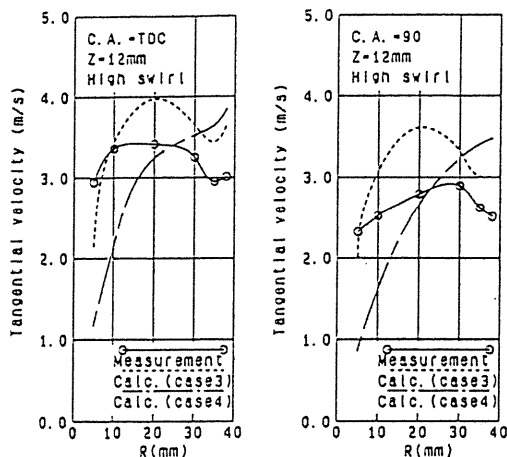

Fig.11 Comparison between measured and calculated tangential velocity (case3 & case4)

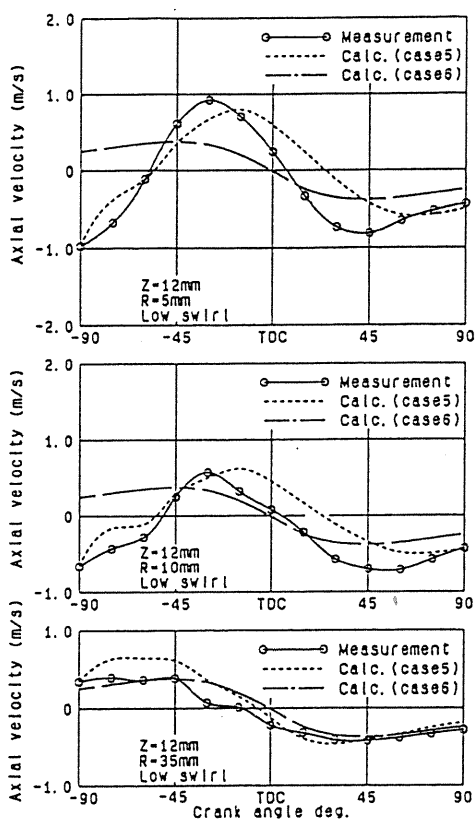

Fig.12 Comparison between measured and calculated axial velocity (case5 & case6)

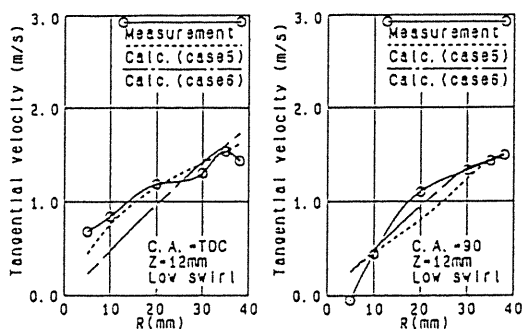

Fig.13 Comparison between measured and calculated tangential velocity (case5 & case6)

## CONCLUSIONS

Dynamic air flow simulation was carried out on the basis of the KIVA code. Simple combustion chamber, having flat piston surface and flat cylinder head surface, was used. Initial conditions were preset for the simulation. The conclusions drawn are as summarized below:

### Case of Low Swirl

Simulation with good accuracy is possible by taking the experimental values as the initial conditions and by properly selecting the parameters of turbulence.

Even if forced vortex is assumed on the basis of the velocity obtained from the swirl ratio of actual engine, simulation with relatively good accuracy is possible if the velocity in axial direction is given accurately.

Simulation with good accuracy is not possible when the initial conditions assumed are forced vortex, in the tangential direction, and the velocity obtained from the linear piston speed equation, in the axial direction.

### Case of High Swirl

Proper simulation is not possible with the method used here even by using the measured data as initial conditions.

## NOMENCLATURE

$\rho$ =fluid density  
 $U$ =velocity vector  
 $P$ =pressure  
 $\sigma$ =viscous stress tensor  
 $\mu_t$ =turbulent viscosity  
 $q$ =turbulent kinetic energy  
 $L$ =characteristic length  
 $A$ =constant  
 $V_\theta$ =tangential velocity

## ACKNOWLEDGEMENT

The authors express their gratitude to Prof. Takeyuki Kamimoto of Tokyo Institute of Technology for providing valuable data and guidance during the course of this study.

## REFERENCE

1. A.A.Amsden, J.D.Ramshaw, P.J.O'Rourke and J.K.Dukowicz "KIVA: A Computer Program for Two and Three Dimensional Fluid Flows with Chemical Reactions and Fuel sprays", LA-10245-MS. (1985)
2. Y.Moriyoshi, T.Kamimoto et al "Measurement and Numerical Simulation of In-cylinder Air Motion of a Transparent Engine.", JSME Vol.53 No.86-0541A. (1986)
3. Fujii et al "A Study of In-Cylinder Gas Flow in 4-Valve Engine Based on 3-Dimensional Numerical Simulation and LDV Measurements." JSAE Review Vol.10 No.4 (1989)