

Simultaneous Measurement of Velocity and Pressure in a Two Stroke Engine

Y. Ikeda, K. Y. Lee, T. Nakajima and R. Matsumoto

*Department of Mechanical Engineering
Kobe University
Rokkodai, Noda
Kobe 657
Japan*

T. Ohhira

Suzuki Motor Co. Ltd.

ABSTRACT

There is close correlation between velocity and pressure in a two stroke engine. This paper presents a simultaneous measurement system of velocity and pressure to understand the flow characteristics induced by the pressure difference while avoiding the cycle variations. A fiber LDV having a good performance was developed and used with an FFT processor. The performance of the system was evaluated by measuring the intake flow velocity and crank angle of the two stroke engine under motored and fired conditions up to 3000 rpm. The results show that the system is a powerful tool to understand the gas behavior of the two stroke engine. Further improvements are discussed also.

INTRODUCTION

Flow characteristics in two stroke engines are governed by gas flow induced by the pressure difference between an inlet port, a crank case, and a cylinder, which influence the performance of the engine strongly. The engines have cycle variation, so that it is necessary to measure cycle-resolved velocity and pressure with high space and time resolution to understand the flow characteristics clearly. Although some reports have dealt with this subject, they have not yet describe the pressure-induced gas flow characteristics accurately and quantitatively, because the flow is complex, combusting, and unstable at high cycle rate. Thus, the measurement system to measure velocity and pressure quantitatively and simultaneously is highly required.

Applications of LDV for gas flow in internal combustion engines have been reported⁽¹⁾⁻⁽⁸⁾. Some reports aim at mainly diesel engines with a large bore and the others are for four stroke engines at low engine speed.

Two-stroke engines have been designed to utilize the gas flow induced by the pressure differences between each component without having intake and exhaust valves. Air is intaken by the negative pressure of the crank case, compressed in the crank case, and then charged in the cylinder by the pressure difference between the crank case and the cylinder. Two stroke engines operate generally faster than four stroke engines, and the reed valve variation is a main influential factor of the gas flow fluctuations. In the sense, the cycle variation of the two stroke engines are not negligible. For quantitative understanding the

pressure-induced flow characteristics in the two stroke engines quantitatively, the simultaneous measurement of velocity and pressure is needed.

LDV measurements up to date have to overcome many problems such as optical access, data rate, seeding, and signal processing to apply LDV for internal combustion engines, the flow of which is highly turbulent and fluctuative. Conventionally, the velocity and the pressure have been measured individually.

The purpose of the present study is to develop a system to measure velocity and pressure simultaneously, apply this system for intake flow measurements, and evaluate the system for further understands of the flow characteristics of high engine speed.

The velocity was measured with a fiber LDV (FLDV) developed and a Burst Spectrum Analyzer (BSA: Dantec). The measurement of velocity, pressure, and crank angle were carried out simultaneously for intake pipe flow under motoring and firing conditions up to 3000 rpm.

EXPERIMENTAL APPARATUS

Test Engine

The test engine used in the study was a crankcase-scavenged two-stroke S.I. engine with a reed valve for motorcycle (made by SUZUKI Motor Co. Ltd.). The major specifications are shown in Table 1. An experimental apparatus is shown in Fig. 1. In order to introduce laser beam into the intake pipe flow, a spacer of 10 mm was inserted, which has the same diameter as the intake pipe and the carburetor pipe as shown in Fig. 2. Two optical windows made of BK-7 (10 mm in diameter and 6 mm in thickness) were installed in the case of forward scatter mode. The optical windows were designed to be removed easily for cleaning.

LDV

The LDV signal was processed by an FFT processor called Burst Spectrum Analyzer (BSA). A mixture of glycerin and water (water ratio: 50%) was atomized by compressed air from a compressor in order that the seeding particles can be adhere to the optical windows. The mean diameter of the particles was fixed to be 3.3 μm , although it can be varied by changing the supplied air pressure.

A fiber LDV (FLDV)⁽⁹⁾ was developed to increase SN ratio and flexibility of the optical access, since the conventional FLDVs have less performance than the fixed type LDV.

Table 1 Specifications of the test engine

Type of engine	Two cycle spark ignition, crankcase compression Single cylinder	
Valve	Reed valve	
Stroke volume	98.17cc	
Bore×Stroke	50×50mm	
Compression ratio	6.59	
Port timing	Exhaust port	open: 97.03° (EO) close: 261.71° (EC)
	Scavenging port	open: 122.65° (SO) close: 239.99° (SC)
Scavenging type	Schnürle	

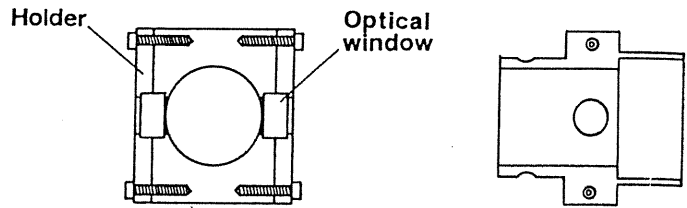
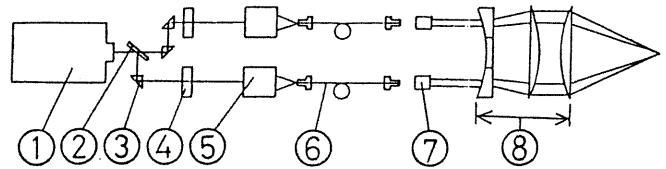

Fig. 2 Schematic layout of the spacer



1. He-Ne laser
2. Beam splitter
3. Prism assembly
4. Dual Bragg cell
5. Focusing lens
6. Optical fiber
7. SELFOC microlens
8. Probe section

Fig. 3 Illustration of the fiber LDV optics

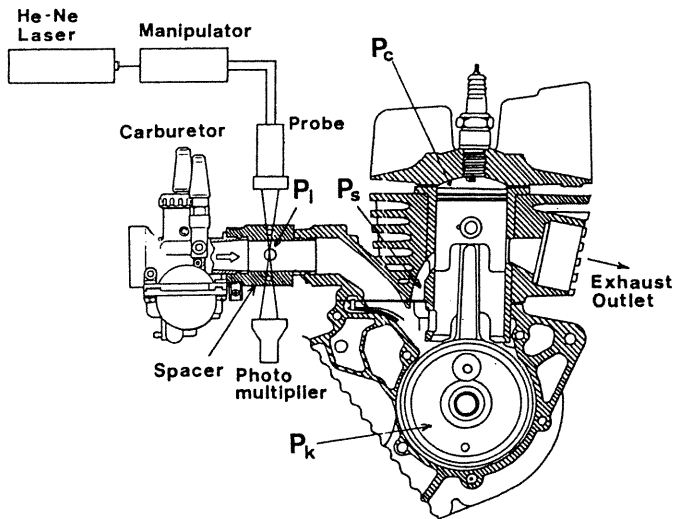

Fig. 1 A cross-sectional view of the test engine

The optical system of the FLDV used is illustrated in Fig. 3. A He-Ne Laser of 25 mW was used and a double Bragg cell of 80 MHz and 90 MHz was used to supply the frequency shift of 10 MHz for the Doppler frequency. The launching efficiency of laser power into a polarization-preserving single-mode fiber of 4 μm in core diameter reached 80 %.

The FLDV probe has a perforated beam expander as shown in Fig. 4. The use of the perforated beam expander contributes to expansion of laser beam diameter incident on the front lens which makes measurement volume small and increases scattered light intensity and space resolution. Furthermore this perforated part can play a role of spacing filter to cut off the troublesome light scattered on the lens surface, and reduce the number of the optical components and hence the probe diameter, which is free from complex optical component adjustments. The specification of the FLDV developed is compared with the others in Table 2. Only as for the SNR parameter⁽⁹⁾ which is determined by the optical system, the FLDV developed has almost ten times as good performance as that of the others.

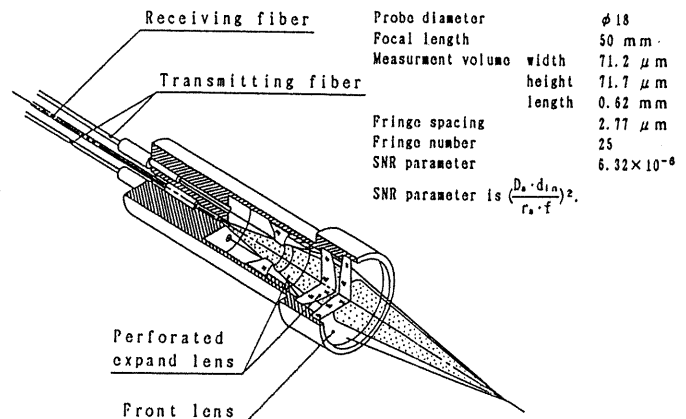

Fig. 4 Schematic layout of the fiber LDV probe developed

Table 2 Dimensions of the measurement volume

	Developed FLDV	Conventional LDV (DANTEC)	Conventional LDV (DANTEC)	FLDV (DANTEC)	FLDV (TISI)	FLDV (KANOMAX)
Wavelength (nm)	632.8	632.8	488.0	632.8	632.8	632.8
Focal length (mm)	50	310	310	50	60	60
Probe diameter (mm)	$\phi 18$	$\phi 120$	$\phi 120$	$\phi 14$	$\phi 14.22$	$\phi 12$
Spot diameter (μm)	71.2	227	79.5	149	140	130
Spot length (mm)	0.62	2.36	0.83	1.87	2.4	2.89
Fringe spacing (μm)	2.77	3.28	2.53	3.97	3.87	7.1
Fringe number	25	69	31	37	30	18
SNR parameter ($\times 10^{-8}$)	6.32	0.47	2.29	0.72	0.61	0.29

$$\text{SNR parameter is } \left(\frac{D_s \cdot d_{1n}}{r_s \cdot f}\right)^2,$$

- D_s : Receiving aperture
 d_{1n} : Beam diameter at the front lens
 r_s : Receiving focal length
 f : Focal length

SIMULTANEOUS MEASUREMENT SYSTEM

System Diagram

The block diagram of the simultaneous measurement of velocity and pressure is shown in Fig. 5.

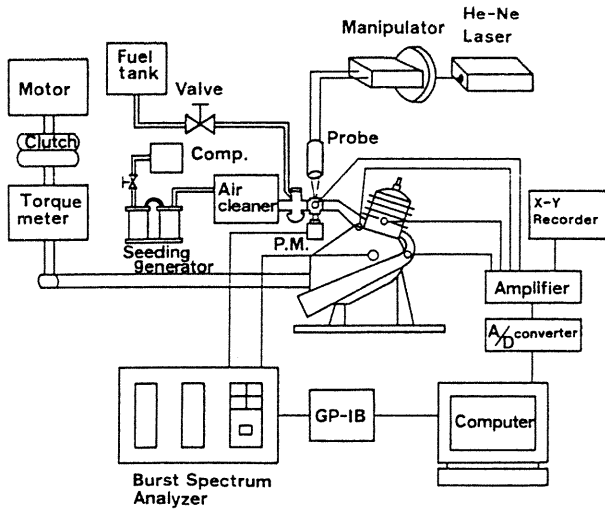

Fig. 5 Block diagram of the system

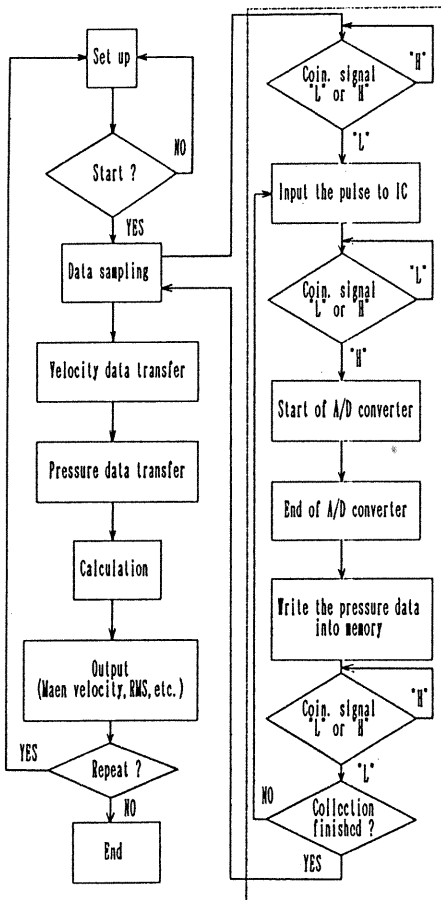

Fig. 6 Flowchart of the signal processing

The Doppler signal from a photomultiplier was transmitted to the BSA together with the crank angle information which was detected by an encoder. The pressure signals were detected by a pressure transducer, amplified by a signal conditioner, and transmitted to the PC computer (NEC: 9801VX) through an A/D converter.

After acquisition of data, velocity information and crank angle information were transmitted from the BSA to the computer memory through a GP-IB interface while the pressure information was directly memorized in the computer. These data were then processed so as to exhibit ensemble averaged velocity and pressure profiles at each crank angle. A flowchart of the signal processing is illustrated in Fig. 6.

Data Acquisition and Processing

The velocity data and the crank angle data were acquired in the BSA and the pressure data was registered in the PC computer. In order that the sampling time of these data coincide with each other, a control circuit with a flip-flop IC (74LS73A) was used as an interface between the BSA and the PC computer as shown in Fig. 7.

The control signals of the BSA for velocity measurements are Coincidence signal and Enable signal. These two signals were connected to the control IC for the pressure data sampling to coincide with the velocity data sampling. The timing chart of the control is shown in Fig. 8. The control process is as follows;

1. Make sure that the coincidence signal is "L". When "H", it means that a particle is traveling through the measurement volume. Wait until the signal becomes "L".
2. Make the enable of the BSA "H" to enable the BSA burst detection. This signal was performed by inputting "L" to the clear terminal of the flip-flop IC through the parallel I/O interface of the PC computer.
3. The coincidence signal is "H" when the burst is detected.
4. When the enable signal and the coincidence signal are "H", the A/D converter starts.
5. When the particle passes through the measurement volume, the coincidence signal becomes "L".
6. When the coincidence signal becomes "L" from "H", the enable terminal of the flip-flop IC becomes "L", which is sent to the BSA in order to disable processing. The disablement is important for removal of the other velocity data during the A/D conversion process and the coincidence of the velocity and the pressure data sampling.
7. After checking the end of the A/D conversion, these data are registered in the memory.
8. Repeat 1 to 7 until enough data is acquired.
9. After acquisition of enough data, the data is transmitted to the PC computer.

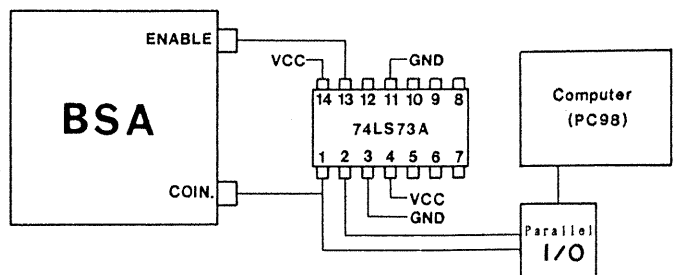

Fig. 7 Interface between the BSA and the computer

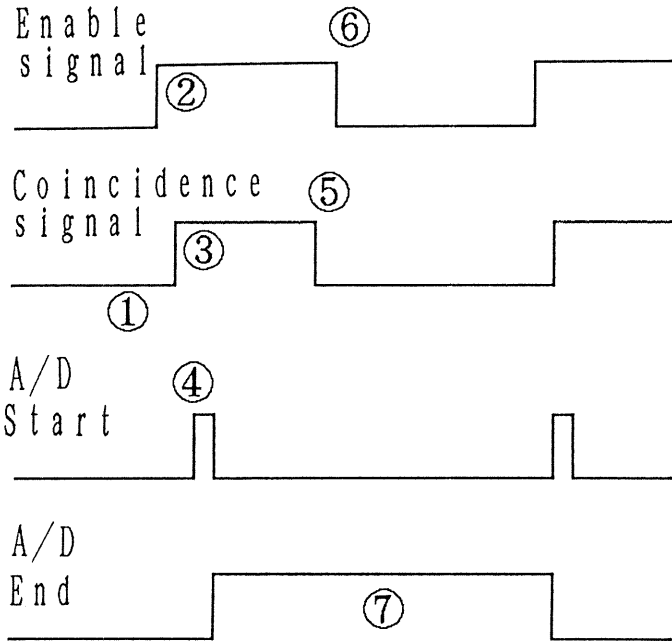

Fig. 8 Timing chart of the control

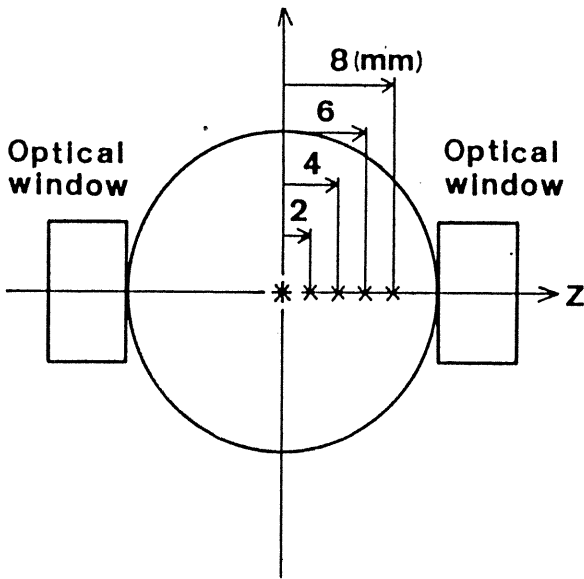

Fig. 9 Measuring points

Measurement Conditions

The velocity was measured at the center of the intake pipe and 83 mm upstream from the reed valve under the motoring and firing conditions. The radial velocity profile was obtained at the five points as shown in Fig. 9. The pressure of the intake flow was measured by the semiconductor pressure transducer (PMS-5: TOYODA) and the reed valve lift was measured by the strain gage pasted on the surface of the reed valve.

The influence of the throttle opening ratio on the intake pipe flow profile was investigated. The cross-sectional areas are illustrated in Fig. 10.

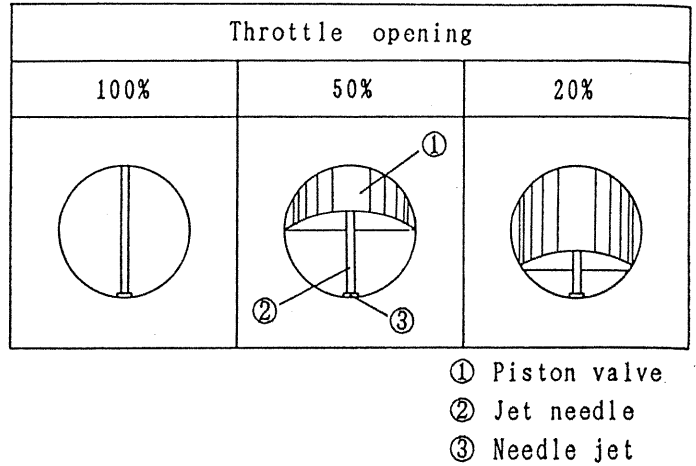

Fig. 10 Cross-sectional area of the throttle opening

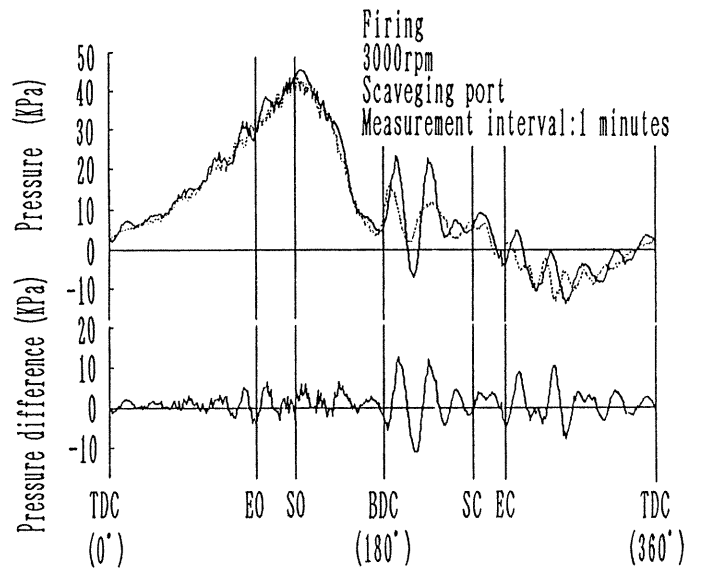

Fig. 11 Cycle variation of the scavenging pressure

EXPERIMENTAL RESULTS

Necessity of Simultaneous Measurement

Two stroke engines with reed valve have cycle variations. The pressure measured at several points have been used for the evaluation of performance of engines. Conventionally, the pressure and the velocity have been measured separately. It is well known that the gas flow has been strongly influenced by the pressure difference between an inlet pipe, a crank case, a cylinder, and an exhaust pipe. The cycle variation therefore causes gas flow fluctuation, which has not been made clear quantitatively.

Figure 11 shows an example of the cycle variation of the pressure at the scavenging port under conditions of 3000 rpm, firing, 200 kHz in A/D sampling, and the throttle opening ratio of 100%. The two pressure profiles were measured at one minute interval. The pressure difference between the two was calculated and shown in the same figure. The result shows the necessity of the simultaneous measurement of velocity and pressure to avoid the cycle variations. For computer simulations of the flow, the pressure-velocity cross-correlations are highly required.

Velocity for various rotation frequency

In order to examine the influence of the rotation frequency on the velocity, the intake pipe flow velocity (U_i), the intake pipe pressure (P_i), the scavenging pressure (P_s), the exhaust pipe pressure (P_e), and the reed valve lift (h) were measured under motored condition of 1500 and 3000 rpm. The measurement was done at the center of the pipe. The measured results are shown in Fig. 12.

At 1500 rpm, a remarkable velocity increase after BDC was observed, but this disappeared with increase of the rotating frequency. This is because the period of the negative pressure of the scavenging port and the exhaust pipe appears before BDC which causes the reed valve opening motion. At 3000 rpm, the velocity peak observed at 1500 rpm disappears and the gas is intaken at the crank angle of 220° when the reed valve opens due to the pressure difference. The velocity intaken timing is shifted to crank angle of 220° was owing to that the positive exhaust pressure shifted downward at 3000 rpm.

The intake flow starts when the reed valve opens and the scavenging pressure becomes negative. This reed valve opening period increases with increase of engine speed, and the reed valve vibration decreases with increase of engine speed.

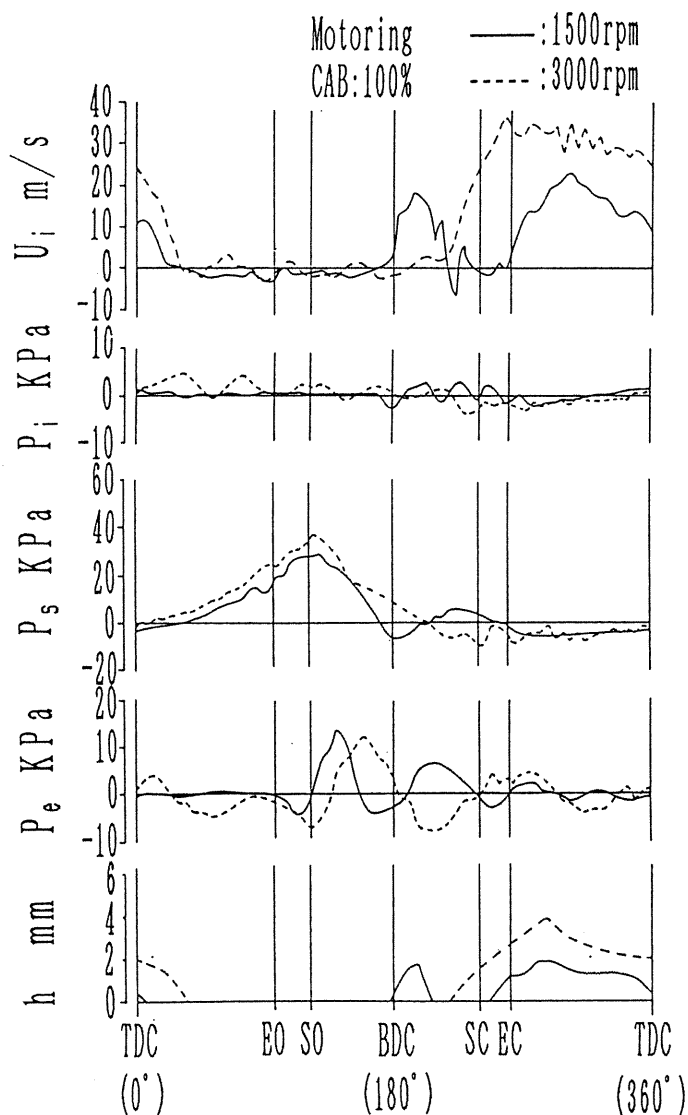

Fig. 12 Velocity and pressure for various rotation frequency

Effect of Throttle Opening Ratio on Velocity

The intake pipe flow velocity (U_i), the scavenging pressure (P_s), and the reed valve lift (h) were measured for the throttle opening ratio of 100 %, 50 %, and 20 % in order to understand the influence of the throttle opening ratio on the intake flow field. The results are shown in Fig. 13.

The measurements were performed at the pipe center and the motored condition of 3000 rpm.

For 50 % opening ratio, the intake mass flow decreased due to the reduction of the effective cross-sectional area for the flow. The velocity profile was not extremely different from that for 100 % and it shows the trend of responding flow to the reed valve motion.

For 20 % opening ratio, the negative velocity appeared during the port closing, which is due to the expansion of the flow and the resulting strong reversing flow.

Comparison of the reed valve vibration for these three throttle opening ratios shows that the reed valve vibration increases with decrease of the throttle opening ratio. The air charge in the crank case becomes insufficient with decrease of the throttle opening ratio, which causes a long negative intake pressure period and the unstable pressure field at the pipe flow. This pressure fluctuation induces the reed valve vibration.

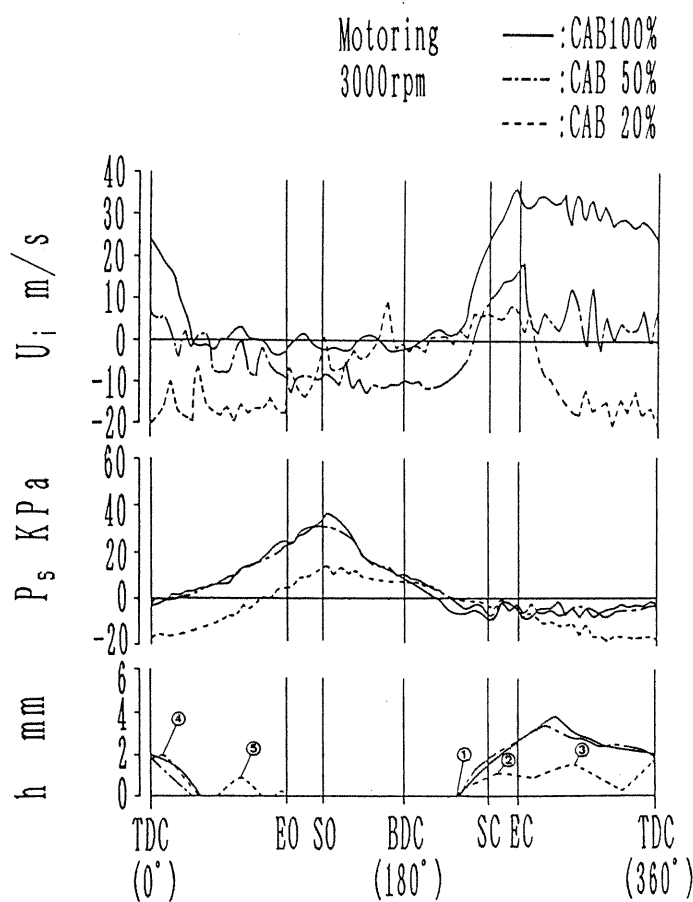

Fig. 13 Effects of the throttle opening ratios

Comparison of Motoring with Firing

In order to make clear the practical intake flow, the intake flow velocity for the firing condition (U_i) was measured and compared with the motored in Fig. 14.

There is not much difference in velocity profile between these two conditions in the expansion stroke, but the remarkable difference was observed in the compression stroke. The start of the intake flow for the firing case delayed until after EC. This delay is supposed to be caused by the reflection of the combustion pressure during BDC and SC, which reduces the scavenging pressure and delays the reed valve opening timing.

Evaluation of the System

It is possible for the present system to measure the velocity and the pressure simultaneously while avoiding the influence of the cycle variation. The measured results show sufficient and quantitative flow characteristics induced by the pressure differences. For further understanding of the pressure inducing flow characteristics, the

following matters should be taken into account: The velocity measurements at high data rate has to be done in order to understand high speed flow in details, which requires a high power laser source, large receiving aperture, high scattering light intensity, and high particle concentrations. Also, the signal processor has to responded to high data rate and requires large memory and processing performance for low SNR signals in real time.

It is also necessary to check that the pressure measured on the wall can demonstrate the flow in the passage exactly.

CONCLUSION

The simultaneous measurement system of velocity and pressure was developed and demonstrated in application for the intake flow characteristics diagnostics of the two stroke engine. It is found that this system is a powerful tool to understand the flow induced by the pressure difference quantitatively while avoiding the cycle variation influence.

The measured results of the intake flow are summarized as follows:

1. The intake flow for motoring and firing was measured for the practical condition.
2. The intake flow at 3000 rpm had less cycle variation, although the velocity and the mass flow were large.
3. The flow for the firing case shows different characteristics from those for the motoring, especially in the compression stroke. This fact shows the strong influence of the reflection of the combustion pressure from the exhaust pipe.

REFERENCE

1. Asanuma, T., Obokata, T., Gas Velocity Measurements of Motored and Fired Engine by Laser Anemometry, SAE Paper No. 790096, 1979.
2. Wigley, G. and Hawkins, M. G., Three Dimensional Velocity Measurements by Laser Anemometry in a Diesel Engine Under Steady State Inlet Flow Conditions, SAE Paper No. 780060, 1978.
3. Fraser, R. A., and Bracco, F. V., Cycle-Resolved LDV Integral Length Scale Measurements in an I.C. Engine, SAE Paper No. 880381, 1988.
4. Foster, R. E., and Witze, P. O., Two-Component Laser Velocimeter Measurements in a Spark Ignition Engine, Combustion Science and Technology, Vol. 59, p 85-105, 1988.
5. Obokata, T., Hanada, N., and Kurabayashi, T., Velocity and Turbulence Measurements in a Combustion Chamber of S.I. Engine Under Motored and Fired Operations by LDA with Fiber Optic Pick-Up, SAE Paper No. 870166, 1987.
6. Bopp, S., Durst, F., and Tropea, C., In-Cylinder Velocity Measurements with Mobile Fiber Optic LDA System, SAE Paper No. 900055, 1990.
7. Lorenz, M. and Prescher, K., Cycle Resolved LDV Measurements on a Fired SI-Engine at High Data Rates Using a Conventional Modular LDV-System, SAE Paper No. 900054, 1990.
8. Lee, K., Ohhira, T., Nakajima, T., and Matsumoto, R., Measurement of Gas Flow Velocity in the Combustion Chamber of a Two-Stroke S.I. Engine by a Laser Doppler Velocimeter, JSME International Journal, Series II, Vol. 33, No. 1, 1990.
9. Ikeda, Y., Nakajima, T., Hosokawa, S., and Matsumoto, R., A Compact Fiber LDV With a Perforated Beam Expander, Measurement Science and Technology, Vol. 1, No. 3, p620-264, 1990.

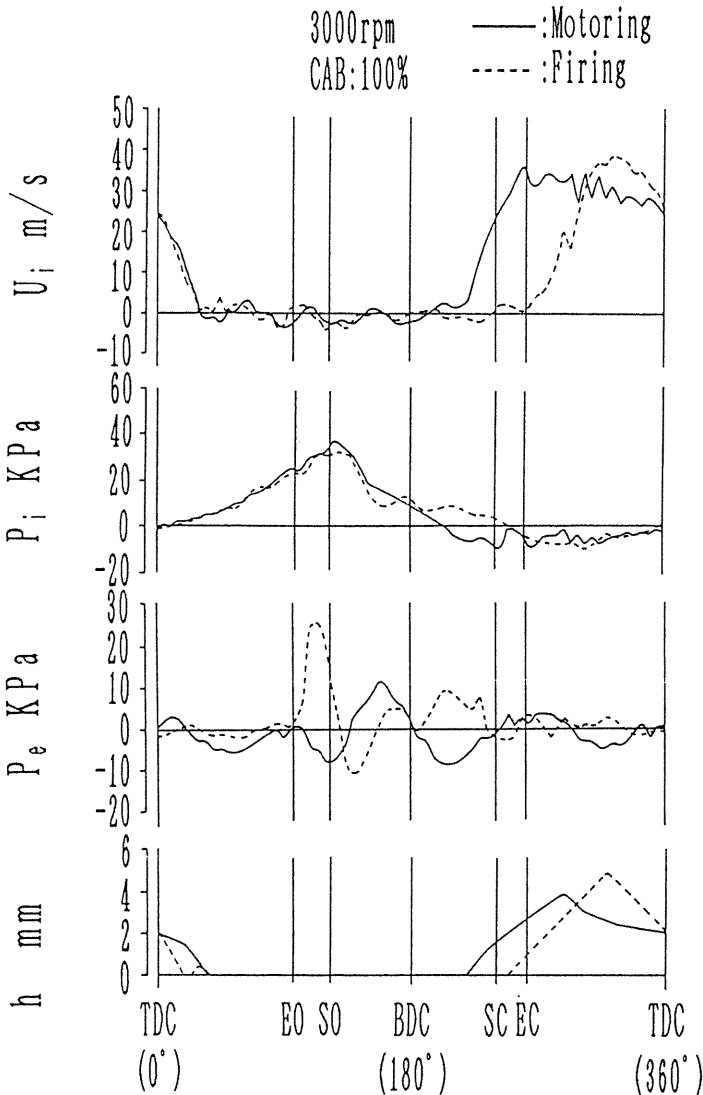

Fig. 14 Comparison of velocity of the motoring and the firing