

# Gas Velocity Stability Measurements in the Initiation Region of an SI Engine

M.J.Bennett, N.S.Girgis\* and M.Nakayama

*Department of Mechanical Engineering  
Gunma University  
1-5-1 Tenjin-cho  
Kiryu 376  
Japan*

*\* Department of Mechanical Engineering  
Coventry Polytechnic, England*

## ABSTRACT

This paper details a system designed specifically to measure the initiation region gas velocities in a motored production engine. The experimental arrangement comprised of a back scatter LDA system, introduced into the engine via the spark plug orifice. Measurements were made in the tangential direction of two cylinder heads, with COMPACT and OPEN combustion chambers. The results were analysed using an ensemble method over a 4 degree window. The stability of successive cycles was analysed using a PDF of the standard deviation within each window. A comparison of normalised PDF figures was used to detect the presence of low frequency cyclic variations. The results showed in general, that a decay of velocities in both chambers produced unstable flows leading to cyclic variations. However the squish region of the compact chamber produced accelerated flows near to TDC. This increased the stability of the flow at this point. The PDF analysis revealed that bimodal velocity distributions could exist in the relatively short time period of a single crank angle window.

## INTRODUCTION

It has been known for some time that the thermal efficiency of IC engines is dependent upon the air motion in them, however at the time of Semenov's early studies (10) little importance was attached to the onset of combustion. Patterson (7) in a study of both single and multi-cylinder engines found variations in IMEP in both the multi-cylinder study, and within one cylinder. This study also suggested that these variations could be minimised within a faster combustion system. Patterson used a figure of 60 PSI/DEG as the high speed combustion pressure rise. Cuttler and Girgis (4) found that pressure rises of above 4 BAR/DEG produced harsh, and in some cases knocking combustion. The increased tendency of this variation in lean burn engines has been investigated by many researchers. Martin et al (15) studied this and also suggested a link between successive high and low peak pressure cycles. In a study aimed specifically at lean burn engines operating near the knock limit Lyon (16) showed that cyclic variation could be limited.

It was suggested by Winsor and Patterson (11) that a high mean gas motion (solid body swirl rotation) could produce a shear effect on the expanding flame kernel. By varying the position of the spark in a known flow field Witze (18) showed that the swirl effect can be used to both enhance the early rate of combustion, and limit cyclic variation. The shear effect produced in the high gas flow position was seen to increase the area of the flame at an early stage. However both Witze (18) and Kalghatgi (3) found an upper limit to the gas motion, through which the early rate of combustion could be increased.

The effect of smaller scale flow fluctuations on the initiation stage of combustion has been difficult to quantify due to the inability to measure the required parameters. However with the advent of Laser based measuring systems, Witze (12), Bradley et al (2), Ball et al (1) and Rask (9) are among the many researchers to use this technique to study small scale flow fluctuations. Keck et al (17) show both bulk motion and small scale fluctuations 10 DEG after ignition. Kalghatgi (3) proposed that both turbulence and bulk motion affect the early stages of combustion. The effect of turbulence may be thought of as increasing the reaction area. Through this increased area a greater rate of heat transfer is possible, such that the flame kernel spreads at a faster rate. However as with the bulk gas motion there is a limit to this method of enhancement (2). The Laser based measurement techniques mainly used in the above studies have evolved to give high data rate information, although not always in the initiation region of realistic engines. However the reduction of this data to give both mean and turbulent flow is difficult. The correct methods are considered by some (9) to depend upon the required results.

The objective of this study was therefore to commission a system to allow high data rate measurements in the initiation region of realistic engine configurations. The data rates were to be high enough to allow detailed cyclic analysis to be carried out. The analysis methods were required to give both mean flow and flow stability information.

## EXPERIMENTAL ARRANGEMENT

OHV ENGINE The engine used for this

investigation was a further development of that reported by Cuttler and Girgis in reference(4). It was a single cylinder engine type adapted from a production cylinder block, full details are listed in appendix (B). The arrangement was developed specifically to allow high speed photography within a variety of chamber types. Further development work on the engine was required such that high data rate LDA readings could be taken in the vicinity of the spark plug.

The original intention was to utilise the same "through the piston" method for the LDA system, as shown in figure (1). However when this was tried the highest data rates attainable were not sufficient for cyclic analysis to be performed. Although high data rates could be obtained with a static engine, the area on the piston crown directly under the inlet valve became contaminated with seeding after a very short time period. As the LDA measuring volume was situated between the valves, one beam would become partially obscured.

LDA BEAM INTRODUCTION Figure (2a) shows the second method used to introduce the LDA beams into the engine. The spark plug has been replaced by a dummy probe holding a small achromatic doublet. The seal on both sides of the lens is provided by two simple 'O' rings as shown in figure (2b). This method allowed the LDA beams to be accurately focused using preset targets, which were then removed prior to testing. As this method provided less optical components for the LDA beams to pass through, the potential for higher data rates was obvious. A second advantage of using this technique was the ability of the last focusing lens to produce a larger angle between the LDA beams. This produced a shorter measuring volume, in addition to moving the two input beams away from the field of view of the back-scatter P.M. tube. The use of this final lens altered the MHz per M/S calibration figure. This effect was corrected using a formula based on the separation of the lens' surfaces. This formula is developed fully in reference (14).

DATA CAPTURE AND PRIMARY PROCESSING Each burst was fed to a HARWELL type 2 FILTERBANK. The FILTERBANK consisted of a set of analogue filters tuned to resonate at a sharply defined centre frequency. The output of the complete set of filters was continuously scanned and the dominant output was recorded as the burst frequency occurring in that time period.

Before each test a preset region of the engine cycle was determined as the test region. Both the resolution and the width of the total sampling window could be changed. High data rates were possible with long time period windows (10 deg.), however all the data in any set window would be labeled with the same central crank angle figure. To avoid the effects of crank angle broadening mentioned by Rask (9), the maximum time delay between each LDA window was set at 1/3 of a degree.

#### DATA PROCESSING METHODS

The first requirement of the data processing package was to remove the frequency shift velocity from each burst signal. The velocity signal captured from the engine was highly irregular, with flow reversals sometimes occurring. If a

relatively large frequency shift was employed during a low gas motion section of the cycle, the burst frequency captured would be that corresponding to the frequency shift. Drain et al (19) specify the use of frequency shift of which the magnitude is always a minor part of the total burst signal captured. However this requires some prior knowledge of the flow field. It was not thought practical to employ a large variety of shift magnitudes, as their effect was not fully understood. To remove the dominance of the shift frequency, the data reduction software was configured such that the true velocity had to differ from the shift modulus by a minimum M/S figure. If this difference was not of the required magnitude, the data point was rejected from the data set. To monitor the data rejection rate, a percentage figure was evaluated at the completion of each data set stating how many times this FREQUENCY SHIFT INHIBIT criterion had been invoked. In practice it was found that the F.S.I. figure would be either above 90% or below 5%. The higher figure denoting a region in which the velocity was so ill defined that only the frequency shift modulus was captured.

It was known from previous investigations using a back scatter LDA system that a large spread of data could be recorded in a short time interval. In stationary velocity systems it is relatively easy to remove this spurious data once a preset variance limit (3-5 std. dev.) has been chosen. In IC engines this is a more complex process as the variance limit calculation is based on a mean figure. To allow this technique to be used the complete data from each engine cycle was split into 4<sup>o</sup> crank angle windows. This figure was selected as the minimum time period in which a sufficient number of data points (150-200) existed to allow accurate statistical analysis. Within each window, both the mean and the Std. Dev. were evaluated. For each data point the following function was then calculated:

$$\text{DELTA} = \frac{V_i - V_m}{\text{Std. Dev.}} \dots\dots\dots (1)$$

Using this delta function the extent of the variation of individual points from the ensemble window mean could be evaluated. A histogram plot of the DELTA function was used to check if any spurious data had been captured. The software was configured to run in a batch file mode within the MINITAB statistical package.

In addition to being used as a screening process this method was extended to allow stability analysis of successive cycles, within the pre-determined crank angle windows. The final histogram function from each window was normalised on a percentage basis, such that the maximum sample count of any one velocity, in a set window, was 1.

#### DISCUSSION OF RESULTS

MEAN FLOW Figure (3) shows the velocity traces from both the OPEN and COMPACT chambers, from 250 DEG to 350 DEG. The measuring volume was in position (1) as shown in figure (5). In this test the engine speed was varied from 750-1200 rpm. Although it is difficult to predict bulk motion from single point measurements, the general decay of the gas motion after the inlet valve closure

can be seen. The COMPACT chamber is seen to decay at an earlier stage (280 DEG), this is thought to be due to the greater friction effects of the small combustion chamber in this cylinder head.

The data from the COMPACT chamber shows reveals some degree of speed scaling, with all three speeds becoming similar in the later stages of compression. The effect of the squish region in this chamber can be seen with the rapid acceleration of the gas flow, at all speeds, after 335 DEG. In the OPEN chamber however there is no such acceleration. There is a marked similarity between the two chambers from 305-315 DEG, where the flow is accelerated in all cases except the 750rpm/OPEN chamber test. In this case only the early stage of compression, 250-280 DEG, shows any resemblance to the two higher speeds.

Although the gas velocity at all three speeds decays from 315 DEG the 750 rpm case is markedly different. Appendix A shows the OPEN chamber, and the position of the spark plug aperture between the the valves. The orifice is positioned in a slight recess. The measurement location (2 on diagram 5) was at the edge of this recess, and it is thought that some flow separation could take place, possibly forming a recirculation zone within the recess.

Figure (4) shows the effect of normalising the mean gas velocity against the average piston speed. The higher intake flow of the OPEN chamber can be seen, attaining over 5x the mean piston speed. The decay of this velocity towards TDC is again shown, with all speeds tending towards zero gas motion. A subsequent test on this chamber revealed that the post TDC flow field, in a motored state, continued this decay process. Although the presence of combustion would alter this flow pattern, it is not thought that large scale bulk motions would occur as a result of this. This confirmed the findings of a previous photographic study (4) which showed that the burnt/unburnt mixture had a very low solid body swirl rate.

The speed scaling of the COMPACT chamber is more organised. The gas motion appears to have a more direct relationship with the mean engine speed. As with the OPEN chamber the lowest speed does show some difference in the 320-340 DEG section. This would suggest that a low speed flow structure is dominant, regardless of the chamber type. Between 340-350 CAD the engine speed/gas motion relationship appears to be linear. This is significant as it could allow a prediction of the gas motion over a wide range of engine speeds, at the time of spark initiation.

MEAN FLOW SPATIAL HOMOGENEITY The variation in both spark energy and breakdown position has been shown by many researchers (6,3) to be a possible cause of cyclic instability. Figure (5) shows the result of a measurement volume traverse within the immediate vicinity of the spark plug.

The effect of the spark plug recess in the disc head can be clearly seen. The velocity profile of each trace is similar, suggesting that all three locations are being influenced by the same large scale flow motion. However the difference in numerical values shows that there are large velocity gradients present. Position 3 (nearest the plug), shows low gas velocity throughout the compression stroke, with negative values occurring from 305 DEG onwards. The data from position 1 (farthest into the chamber) may indicate the bulk gas motion, as this location

was outside the plug recess. This large variation in gas velocity over such a small spatial change (Pos. 1 -> Pos. 3 = 6. mm) cannot be beneficial to stable flame initiation. The extent of this variation, including velocity reversals, could produce the flame motion variations described by Keck (17).

The same analysis was performed in the COMPACT chamber, with an increased traverse such that position 1' was 12 mm away from the spark plug. The relative homogeneity of this chamber can be seen. There is no plug recess, and the smaller size of the chamber results in a better indication of the bulk motion using this technique. In the time period that the spark would occur (330-345 DEG) this chamber shows far less velocity variations than the OPEN chamber. The potential of this combustion chamber to accommodate a wider range of spark breakdown positions is obvious.

CYCLIC FLOW STABILITY In performing the analysis described in the DATA PROCESSING section it was found that, after the spurious data had been removed, the remaining data would normally lie between +/- 3.5 Std. Dev. in any one 4° window. This would suggest that within this time period the velocity fluctuations follow a Gaussian pattern, however closer examination of successive histograms has revealed this to be untrue. Figure (6) shows the normalised PDF plot, with the respective  $V_m$  and  $v'$  from the OPEN chamber at 750 RPM. The deceleration at 265 DEG is shown on the PDF figure as a bimodal shape. The acceleration from 340 DEG is shown as a dominant single peaked PDF. If the PDF function is compared along side the  $V_m$ ,  $v'$  plot then it can be said that only in single peaked PDF windows, are the average figures a true representation of single existing mean. In a region where there is high bulk cyclic variations the single calculated mean cannot represent the flow system.

The spatial stability of the flow was investigated using this method. Figure (7) shows the respective histograms from the measuring positions shown in figure (5). In the OPEN chamber the data was taken in the last crank angle window before TDC. The effect of the deceleration of the gas can be seen on points (2) and (3), although point (2) is more disorganised. The location of this measuring point, just at the recess level, (Appendix B) is thought to be responsible for the instability of the histogram.

## CONCLUSIONS

- 1) LDA has been used to measure the initiation region flow field in two combustion chamber types of a motored production engine
- 2) The experimental engine was altered to allow lubrication free experimentation up to 1200 rpm.
- 3) The LDA data was processed to give both ensemble mean and cyclic stability information.
- 4) The gas flow data from the OPEN chamber showed that the bulk swirl motion decayed up to TDC. The COMPACT chamber showed a similar trend up to 336 CAD, after which the squish region forced a rapid acceleration of the in-cylinder gas.
- 5) The speed scaling, with respect to average piston motion, of the compact chamber was more

consistent in the later stages of compression.

6) The smaller combustion bowl of the COMPACT chamber showed a greater degree of spatial homogeneity. The effect of the spark plug recess in the OPEN chamber was seen as unsteady/negative flows in the later stages of compression.

7) The cyclic stability of both chambers was directly linked to their ability to produce high speed flows. The flow pattern of the COMPACT chamber was more repeatable in this respect.

The direct conclusions of this study have shown that it is possible to produce a repeatable flow field using relatively high gas velocities. As stated in the introduction, this trend cannot be indefinitely extended. If positive gas motion is required when combustion nears completion, then a correspondingly higher gas flow must exist at the initiation stage. The effects of this high gas motion on the early flame growth need to be further quantified.

#### NOMENCLATURE

DBL - Detonation border limit  
 DEG - Engine crank angle degrees  
 F.S.I - Frequency shift inhibit  
 IMEP - Indicated mean effective pressure  
 P.M. - photomultiplier tube  
 PSI - Pounds per square inch  
 Std. Dev. - Standard Deviation

#### ACKNOWLEDGMENTS

Dr. N S Girgis for his support and guidance throughout this work.  
 The Science and Engineering Research Council (UK) who provided financial support throughout this project.  
 The staff of the Engineering faculties of both Tohoku and Gunma Universities.

#### APPENDIX A - REFERENCES

- 1) Ball W, Pettifer M, Waterhouse C.  
 Laser Doppler Measurements of turbulence in a direct injection Diesel combustion chamber.  
 I. Mech. E Trans. 1983 C42/83
- 2) Bradley et al.  
 Limits to turbulence enhanced burning rates in lean burn engines.  
 I. Mech. E Trans. C46/88
- 3) Kalghatgi G  
 Early Flame Development in a spark ignition engine.  
 Combustion and Flame Vol. No 60. 299-308 1985
- 4) Cuttler D, Girgis N.  
 High speed Photography of knocking and normal combustion in open and compact chambers.  
 SAE Trans. 880195 1988
- 5) Kalghatgi G, Swords M.  
 Flame speed measurements in a S.I. Engine.  
 Combustion and Flame Vol. No 49 163-169 1983
- 6) Kalghatgi G.  
 Spark Ignition, early flame development and cyclic variation in IC engines.  
 SAE Trans. 870163 1987
- 7) Patterson D.  
 Cylinder pressure variations - A fundamental combustion problem.  
 SAE Trans. 660129 1966
- 8) Peters B, Borman G.  
 Cyclic variations and average burning rates in an SI engine.  
 SAE Trans. 700064 1964
- 9) Rask R.  
 Comparison of window, smoothed ensemble and cycle-by-cycle techniques....  
 ASME Trans. 'Fluid Mechanics of Combustion Systems' Conf. 1981.
- 10) Semenov E.  
 Studies of turbulent gas flows in piston engines.  
 OTN. No 8 Nasa.
- 11) Winsor R, Patterson D.  
 Mixture turbulence - the key to cyclic variation.  
 SAE Trans. 730086 1973
- 12) Witze P.  
 Measurement of the spatial distribution and engine speed dependence of turbulent air motion in an IC engine.  
 SAE Trans. 770220 1975
- 13) Witze P, Hall M, Bennett M.  
 Are gas velocities in a motored piston engine representative of the pre-ignition flow motion in a fired engine.  
 SAND 88-8878 Combustion Research Facility, Livermore, California.
- 14) Bennett M.  
 Investigation of the flow characteristics in the spark ignition region of SI engines using Hot Wire And Laser Doppler Anemometry.  
 Ph.D Thesis Coventry Polytechnic 1989.
- 15) Martin J, Plee S, Remboski D.  
 Burn modes and prior cycle effects on cyclic variations in lean burn SI engine combustion.  
 SAE Trans. 880201 1988
- 16) Lyon D.  
 Knock and cyclic dispersion in a spark engine.  
 I. Mech. E. Trans. C207/86 1986
- 17) Keck et al  
 Early burning rates in SI engines and their cyclic variability  
 SAE Trans 870164 1987
- 18) Witze P  
 Effect of spark location on combustion in a variable swirl engine.  
 SAE Trans. 820044 1982
- 19) Drain L, Wigley G, Yeoman M, and Dale B.  
 An analysis of experimental errors in LDA measurements for the ICE engine project.  
 HARWELL AERE-r 9465

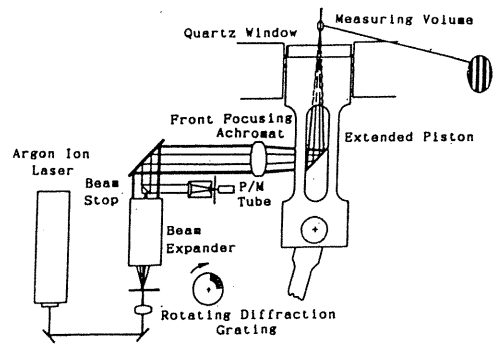

FIG. 1  
EXTENDED PISTON LDA ARRANGEMENT

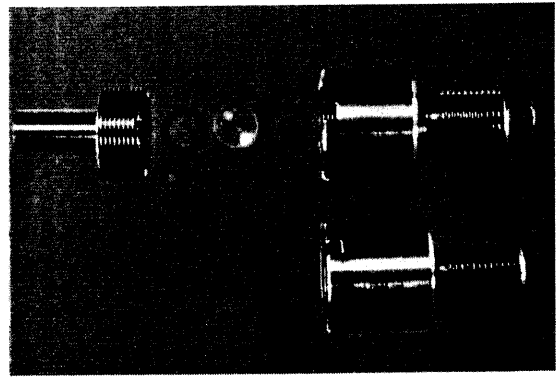

FIG. 2a LDA PLUG PROBE

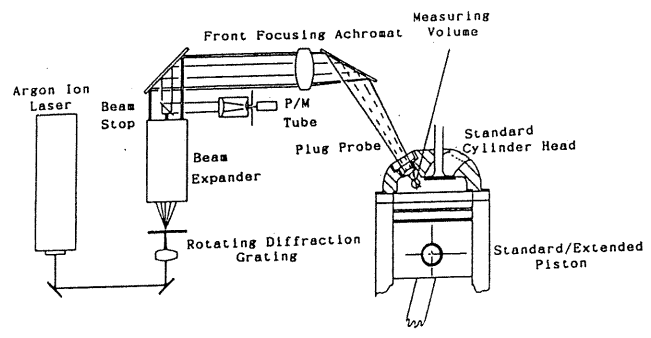

FIG. 2b SPARK PLUG PROBE  
LDA ARRANGEMENT

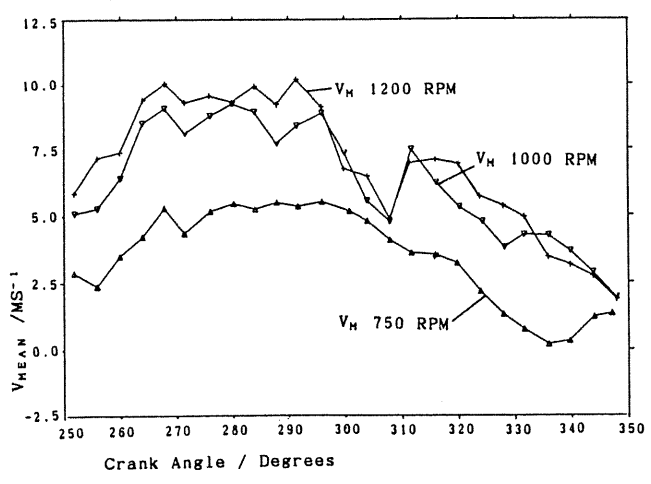

FIG. 3a OPEN CHAMBER GAS  
VELOCITY VARIATION

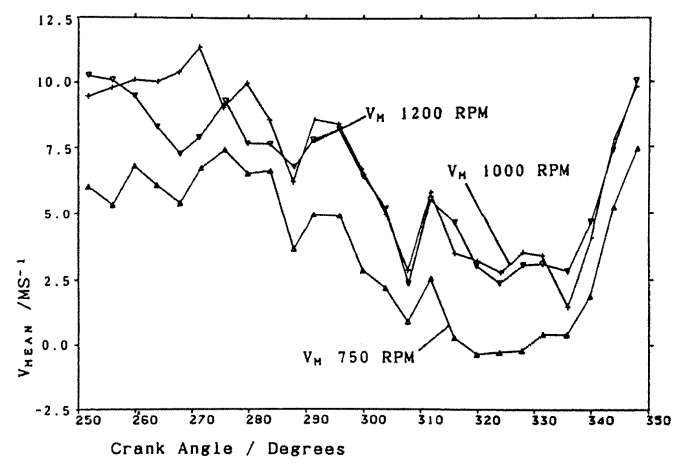

FIG. 3b COMPACT CHAMBER GAS  
VELOCITY VARIATION

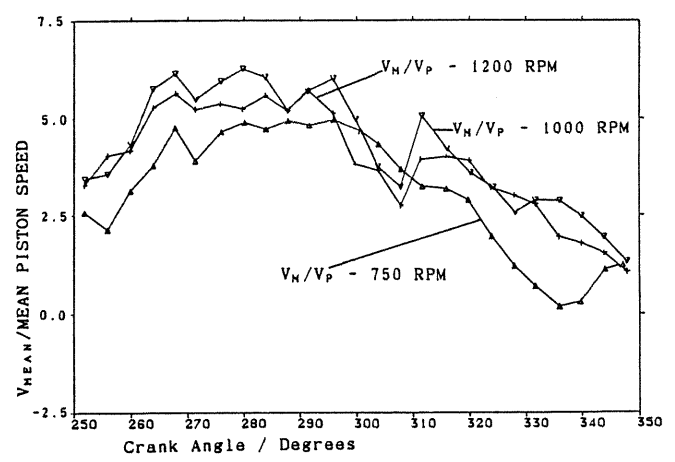

FIG. 4a OPEN CHAMBER NORMALISED  
GAS VELOCITY VARIATION

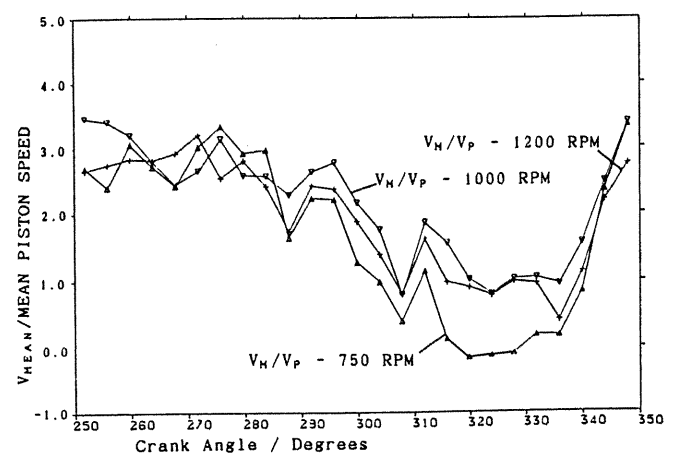

FIG. 4b COMPACT CHAMBER NORMALISED  
GAS VELOCITY VARIATION

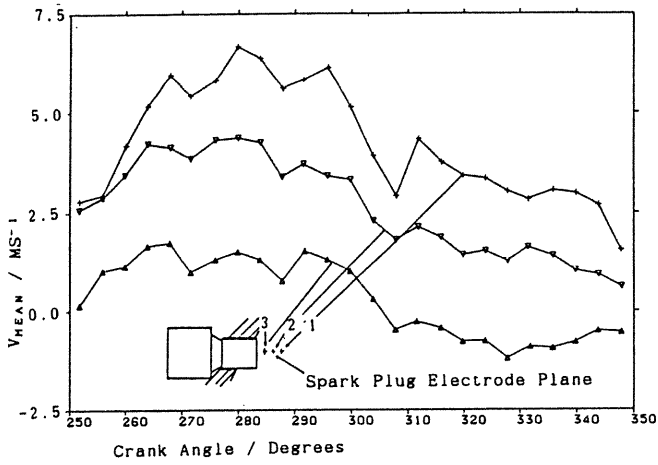

FIG. 5a OPEN CHAMBER SPATIAL GAS VELOCITY VARIATION

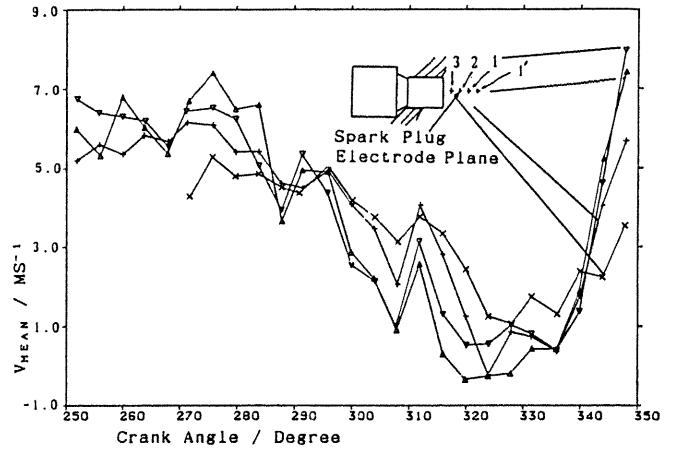

FIG. 5b COMPACT CHAMBER SPATIAL GAS VELOCITY VARIATION

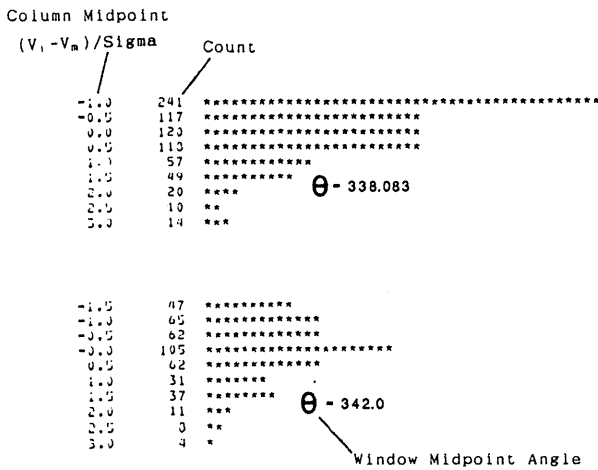

FIG. 6a UN-NORMALISED P.D.F FUNCTIONS

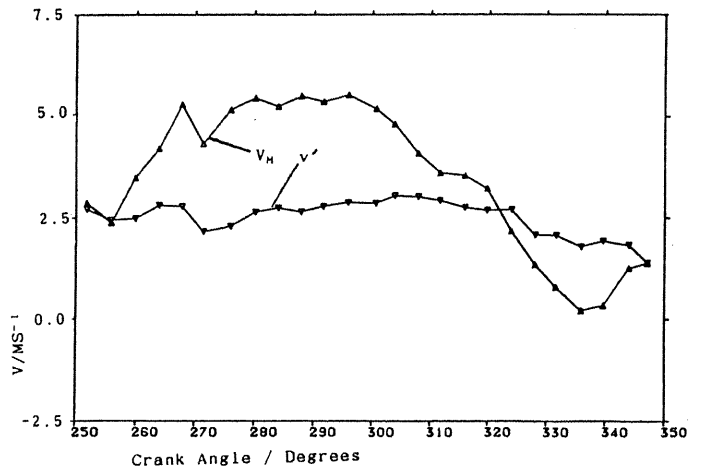

FIG. 6b V<sub>M</sub> , v' / CRANK ANGLE

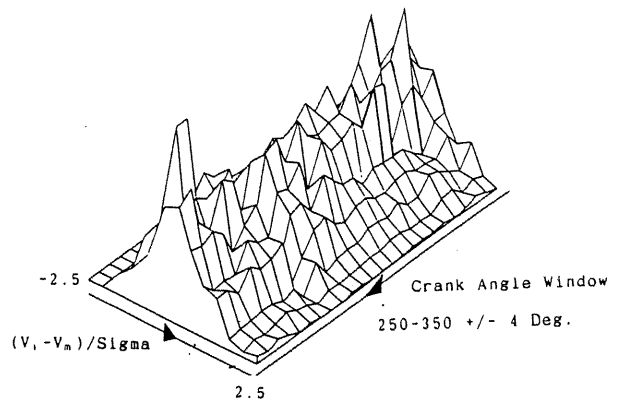

FIG. 6c NORMALISED P.D.F. PLOT

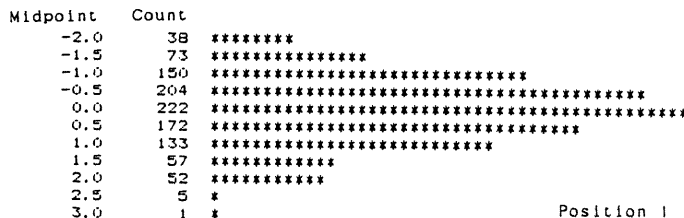
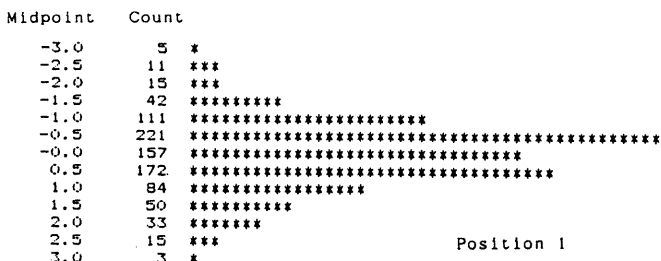
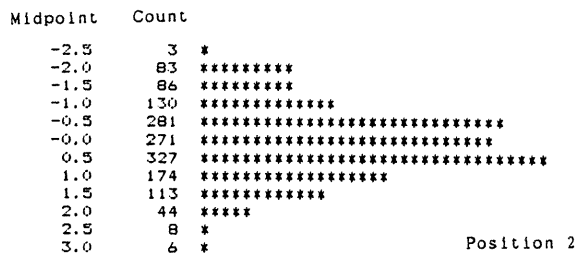
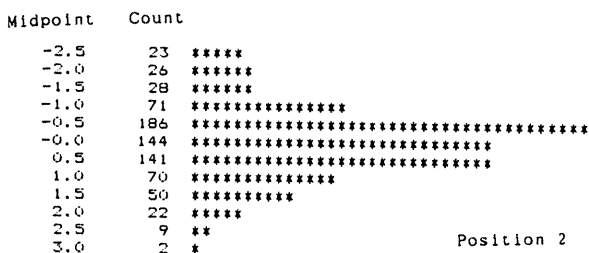
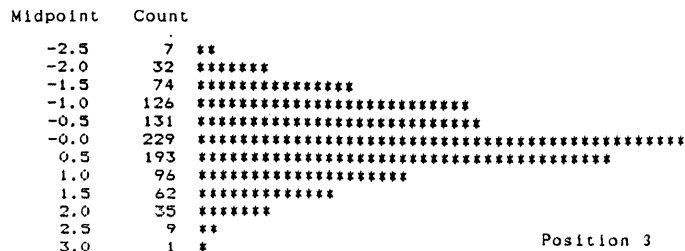
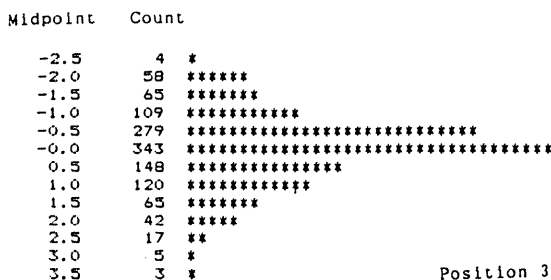

FIG. 7a OPEN CHAMBER SPATIAL VARIATION IN VELOCITY STABILITY (750 RPM)  $\Theta = 298.00$       FIG. 7b COMPACT CHAMBER SPATIAL VARIATION IN VELOCITY STABILITY (750 RPM)  $\Theta = 346.00$

APPENDIX B - OHV Engine and LDA Data

OHV Engine And Combustion Chambers

Conrod length	148.10 mm
Crank throw	44.45 mm
Bore diameter	85.00 mm
Swept volume	498.00 cc
Piston crown	flat
Inlet valve closes	41 deg. ABDC
Exhaust valve opens	61 deg. BBDC

Combustion Chamber Configurations

Type:	Compact (May)	Disc (Open)
Shape:	Bowl under inlet	Flat Disc
Cl. Vol (bowl)	36.6 cc	-
Spacer Plate Thickness	1.1 mm	9.0 mm
Compression Ratio	12:1	9:1

LDA Specifications

Beam Separation	45 mm
Focal length of front lens	300 mm
Beam intersection 1/2 angle	4.28 deg.
Measuring volume diameter	2.46 micron
Measuring volume length	0.328 mm
Velocity/Frequency conversion	3.436 m/s/MHz
Diffraction grating speed	600 rpm
Frequency Shift	1.3616 MHz

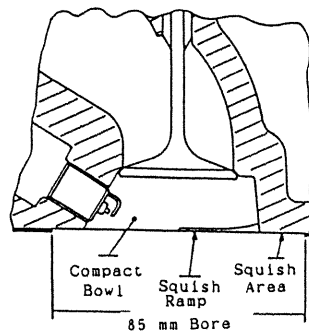
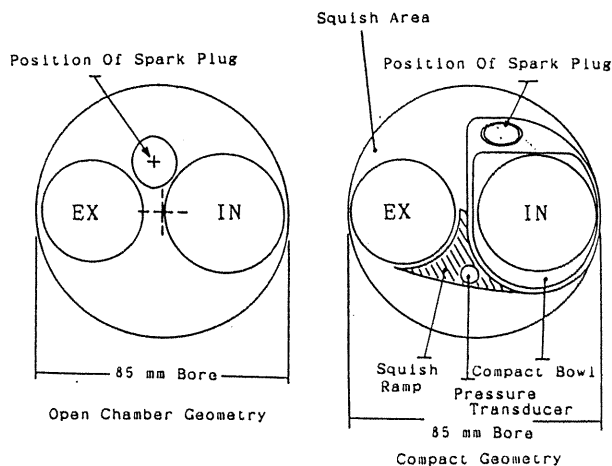

Compact Chamber -Cross Sectional View