

An Optical Research Engine for the Study of Two-Stroke Cycle In-Cylinder Phenomena

R.M.Green

Sandia National Laboratories

P.O. Box 969

Livermore, CA 94550

U.S.A.

B.J.Cousyn

CORIA, University of Rouen

Mont Saint Aignan, France

ABSTRACT

In this paper, we describe a new optical research engine that was designed to study two-stroke cycle engine processes using laser diagnostic techniques. This engine features cross-port scavenging, externally compressed air intake through axial transfer ports and air-forced, direct fuel injection. We illustrate the modular nature of the engine components which allows the convenient modification of the basic engine configuration. We discuss the system used for engine control, the strategy used to obtain realistic engine operation and describe our limited characterization of the engine performance. Finally, we present some typical results of our initial observations of in-cylinder phenomena.

INTRODUCTION

The two-stroke cycle engine offers some advantages as a power source for transportation applications. Since this type of engine operates with a power stroke on each revolution of the crankshaft, its displacement capacity need be only half that of an equivalent four-stroke engine. This results in a smaller, light weight engine with a potential improvement in vehicle fuel economy. In addition, the mechanical complexity can be significantly reduced. The economic significance of these advantages is attracting the attention of the auto industry in the current environment of fierce international competition in the automotive market place.

Unfortunately, the advantages of the two-stroke cycle engine are accompanied by some problems (1). In a port-scavenged engine where the fuel and air are mixed in an external carburetor, some of the fresh charge entering the cylinder can be "short-circuited" out the exhaust ports which are open at the same time. This results in a reduction in the fuel efficiency of the engine as well as an increase in the unburned hydrocarbons in the exhaust. This latter problem essentially eliminated the use of two-stroke cycle engines in automotive applications as environmental concerns grew and began to control the design of automotive engines.

The development and application of microprocessor-based engine control systems and electronic fuel injection equipment has stimulated an interest in the use of direct, in-cylinder fuel injection in spark ignition engines (2). This DISC (direct injection stratified charge) technology has renewed the automotive engine designer's interest in two-stroke cycle engines, since by injecting the fuel directly into the cylinder after the exhaust port closes, the problem of unburned fuel in the exhaust is eliminated. Recently, the Orbital Engine Company of Australia introduced a three cylinder two-stroke cycle engine that meets the 1990 US Federal emission standards. This development has created a great deal of interest in Japan (3) and the European Community (4), in addition to the United States.

At Sandia National Laboratories, we have an ongoing research program aimed at improving our understanding of the fundamental phenomena occurring in internal combustion engines. Our research is intended to compliment the development work going on in industry, and represents a portion of the government's effort to provide technology development support to industry. This paper will describe our current effort at responding to the needs of this developing technology.

BACKGROUND

The crankcase-scavenged two-stroke cycle engine was patented in the late 1800's. Since that time, the engine design has evolved considerably. The processes occurring in a two-stroke cycle engine are strongly dominated by gas dynamic and fluid mechanic effects, and these areas of technology have most strongly influenced the evolution of this engine. Prior to 1980, experimental studies of scavenging were mostly indirect assessments of the in-cylinder flows (5) using steady flow rigs or open cylinder configurations. While these techniques are somewhat crude by today's standards, this research was quite useful in guiding engine designers, and resulted in significant advances in the designs.

Theoretical studies of two-stroke engine processes can be grouped into two categories, phenomenological modeling (6) and multidimensional modeling (7). The use of these techniques has met with a reasonable degree of success. Unfortunately, there is only a limited data base available to evaluate the results of the models under realistic engine conditions. Recent studies using laser Doppler anemometry (8), along with others currently underway employing

Work performed at the Combustion Facility at Sandia National Laboratories and supported by the U.S. Department of Energy, Energy Conversion and Utilization Technologies Program.

optical diagnostics, should help improve our theoretical capabilities and lead to a better understanding of two-stroke engine processes.

In the sections that follow, we will describe a new optical research engine that has been designed to allow the use of optical techniques to study in-cylinder phenomena in a realistic environment. The following sections contain a discussion of our research philosophy and a description of the engine along with the results of a limited characterization of the engine operation. We will then highlight the results of some initial observations. Finally, we will discuss our future research direction in the context of the current needs of the engine design community.

OPTICAL RESEARCH ENGINE DESCRIPTION

Our objective in establishing this new experimental facility was to provide a means to study the important in-cylinder phenomena occurring in a two-stroke cycle engine using two-dimensional planar imaging techniques. Because fluid mechanical processes control the operation of these engines, we took special care in our design not to compromise these important mechanisms. On the other hand, there are many possible design configurations of a port-scavenged two-stroke engine. We expect the generic configuration we chose will provide a good simulation of actual engine scavenging flows, yet allow the flexibility to install windows to observe these flows with the engine operating.

We adopted a second design objective wherein we tried to maintain a high degree of flexibility. The motivation for this philosophy was to provide the means to easily modify the engine configuration. Unfortunately, the level of flexibility that we desired eliminated the option to include crankcase scavenging. This is because the crankcase, transfer ports and cylinder ports are so closely coupled in the engine structure, it is difficult to modify one of these areas without significantly affecting the others. Thus we elected the blower scavenged design. We believe that this compromise is reasonably justified in that many of the important processes are only marginally influenced.

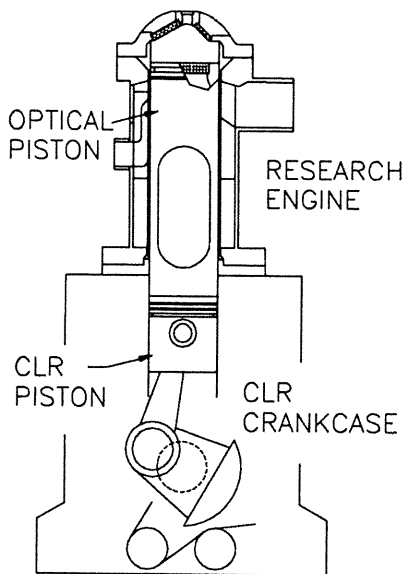

Figure 1. A schematic layout of the Sandia optical research engine

The basic layout of our research engine is illustrated in Figure. 1. The engine consists of a custom-made cylinder head with a piston and cylinder extension adapted to a Cooperative Lubrication Research (CLR) engine as shown. The CLR engine was developed years ago for use by oil companies to evaluate lubricants. It is strong and reliable at engine speeds up to 4000 RPM, and includes a large flywheel and an integral balancing system. We simply removed the head of the CLR engine and attached the extended piston to the CLR piston and the extended cylinder to the CLR cylinder block as shown in Figure. 1. We chose this configuration in order to use a window in the dome of the piston and view the combustion chamber from below. In the current configuration the combustion chamber is totally contained in the head. The bore and stroke are both 95.3 mm and the compression ratio is about 6:1.

PISTON ASSEMBLY. The extended piston is made of aluminium and is operated without lubrication. The top 3 cm of the piston is connected to the bottom section by a threaded joint. This design allows us to change the configuration of the piston dome, such as replacing the flat window with a bowl-in-piston having a window in the bottom of the bowl. The lower section of the piston has two diametrically-opposed, longitudinal slots that allow us to insert a stationary support for an inclined mirror. This enables us to view the combustion chamber through the window in the top of the piston.

We use three piston rings in the current design. All of the rings are made from a graphite-filled polyimide (Vespel, a registered trademark of Dupont) material which allows unlubricated, elevated temperature operation. The top ring is a sealing ring featuring an overlapping joint to eliminate the possibility of ring erosion due to leakage through the gap. The second ring is located just below the sealing ring and is also made of Vespel. It is designed as a rider ring and is intended to prevent the piston from contacting the unlubricated cylinder wall. A third ring is located down the piston at a position where it is just below the ports in the cylinder wall when the piston is at top dead center (TDC). This ring is intended to restrict gases from entering the area below the piston occupied by the inclined mirror or other optical components.

CYLINDER ASSEMBLY. The cylinder assembly consists of an outer structural housing, the cylinder liner and the transfer ports. The outer housing is designed to support the liner and carry the load from the head to the crankcase. The upper flange of the housing supports and locates the top of the liner and maintains its concentricity with the piston. This flange is designed with coolant passages for thermal control of the top portion of the liner. The lower flange of the housing is attached directly to the CLR crankcase at the plane of the CLR piston top.

The cylinder liner is made from mild steel, and except in the area of the upper flange, has a wall thickness of 3.2 mm. The porting configuration and the directional characteristics of the transfer ports was scaled from the design of a Suzuki marine engine, and represents current technology.

The transfer ports are made from cylindrical segments of aluminum, and are designed to fit between, and be sealed to, the intake and exhaust flanges in the outer housing and the port openings on the outer surface of the liner. The intake transfer ports channel air from the pressurized in-

take manifold up along the outside surface of the liner, and then into the cylinder as a directed jet. The spatial orientation of the transfer ports is shown in Figure 2, where we show a horizontal cross section of the engine cylinder. Notice that the horizontal orientation of the side intake ports directs the flow back toward the "boost ports" which are opposite the exhaust ports. The vertical orientation of all the ports directs the inlet flow up at an angle of about 45 degrees. The exhaust port segment simply channels the exhaust from the liner ports directly out the housing to the exhaust manifold.

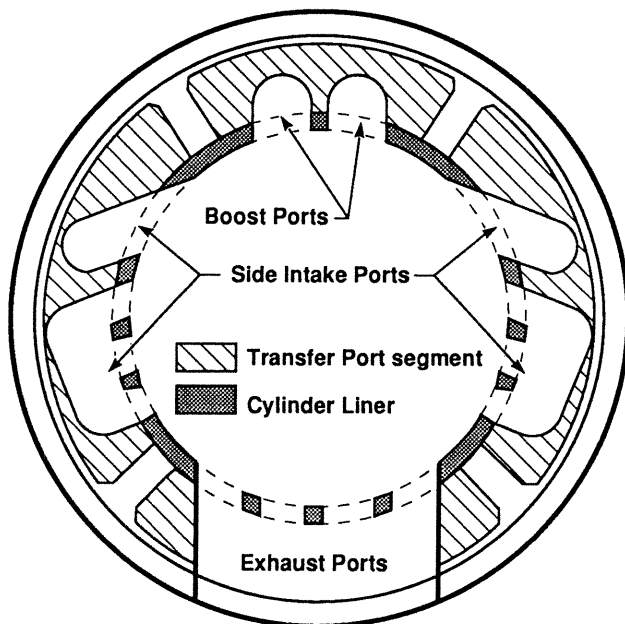

Figure 2. A cross sectional view of the cylinder in the horizontal plane illustrating the transfer port segments and the spatial characteristics of the intake ports.

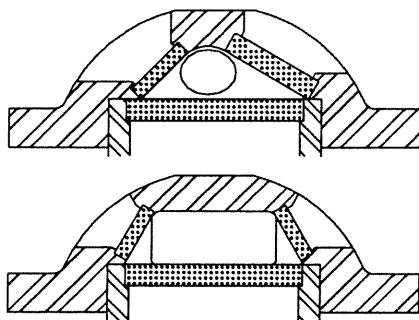

Figure 3. Orthogonal, cross sectioned sideviews of the cylinder head showing the shape of the combustion chamber and the location of the windows (shaded).

CYLINDER HEAD. The cylinder head illustrated in Figure 3 is designed with four windows in the combustion chamber. The layout of the windows is intended to accommodate the tumbling mean flow created by the orientation of the transfer ports, and allow this flow to loop through the combustion chamber for effective scavenging of residu-

als. In addition, the window configuration allows the convenient entry and exit of planar sheets of laser light. We chose to make the windows from optical quality, crystalline sapphire, because of its high strength characteristics.

We fabricated the cylinder head from a solid aluminium block. We circulate a fluid in a channel in the mounting flange which can preheat the windows and head prior to operating, or cool the head while operating.

The window opening is designed with a small inward-facing step outside the window intended to carry the load due to the in-cylinder pressure. We use a silicon-based adhesive to form an interface between the window and head, and a seal against combustion gas leakage. This interface is intended to accommodate the difference in thermal expansion between the window and the head, and to cushion the window from stresses due to warping of the window seat. We have been successful with this technique using Silastic J (a registered trademark of Dow Corning).

In the top of the cylinder head, we have provided for the installation of a spark plug, a pressure transducer and a fuel injector. In our initial work we are using a prototype air-assisted fuel injector on loan from Ford Motor Co. This fuel injector features two solenoid actuated valves; one to admit a desired quantity of fuel into the injector, and the second to admit air at a pressure of 5 to 8 bars. When the air solenoid is opened, the pressure in the injector increases and opens a poppet valve at the nozzle. The fuel is then blown out of the injector by the air, forming a hollow-cone spray. Studies have shown this injector to produce a highly atomized fuel spray (9).

EXPERIMENT CONTROL. In an optical research engine, there is a need to limit the thermal loading of the windows to prevent their failure. This need has been satisfied in the past by operating the engine in a skip-fired mode. However, the combustion process in a two-stroke engine is highly sensitive to the residual products of combustion from the previous cycle. Thus it is important to maintain some degree of continuous operation, since skip-firing would seriously compromise the combustion conditions.

The firing strategy we adopted is a "burst-fired" mode of operation. In this technique we fire the engine for several consecutive cycles, and then motor the engine without fuel injection or ignition for another series of consecutive cycles. This sequence of fired then motored cycles is continued repetitively. Using this firing strategy, we make our measurements on the last cycle in the firing sequence when a reasonable simulation of continuous operation has been obtained. Although this is clearly a compromise of realistic engine operation, our experience has shown that this technique does result in an acceptable simulation of continuous operation. We performed a study of various combinations of fired and motored cycles and found that following seven motored cycles, the third of three fired cycles was a good representation of continuous operation.

PERFORMANCE CHARACTERIZATION

Following fabrication, assembly and checkout, we performed a limited performance characterization of the engine operating at relatively low speed. Our motivation was to determine the operational utility of the engine, identify the operating ranges of the more important control parameters, and investigate the performance sensitivity to these

parameters.

Figure 4 illustrates a typical pressure history for an engine speed of 600 RPM, a near-stoichiometric equivalence ratio, methanol fuel, and a moderate scavenging pressure. The pressure curve illustrates the general nature of the engine operation, and indicates that under these conditions, engine performance is reasonable. That is, the heat release occurs at about the proper time in the cycle, and at a sufficiently rapid rate. The times of exhaust port closing and opening (90 degrees after and before bottom center) are easily observed in the pressure history, and the resulting IMEP of about 7.5 bar is typical for an engine of this type.

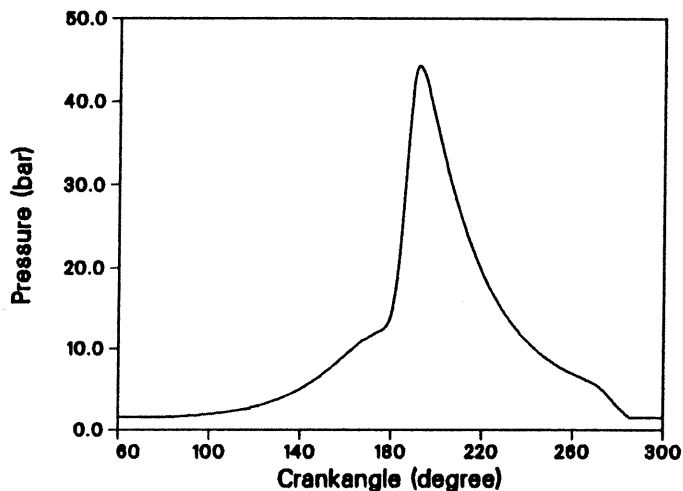

Figure 4. A typical cylinder pressure history for engine operation at moderate load, burning methanol.

In an effort to establish the sensitivity of the engine performance to the important operating parameters, we determined the IMEP from a cycle-averaged pressure history as a function of some of the operating parameters. We considered the spark timing, the scavenging air pressure, and the fuel injector air pressure. These measurements were made at an engine speed of 480 RPM, moderately heavy load, and start of injection at the time of exhaust port closing. The influence of the spark timing is illustrated in Figure 5. This spark sweep indicates an optimum spark timing of about 20 degrees BTDC. Figure 6 describes the effect of fuel injector air pressure. Notice that as the pressure is increased, the engine performance first improves then levels out. It is apparent that up to a pressure of about 6.6 bars, the increasing air pressure improves the effectiveness of the fuel injector through better atomization, penetration and/or mixing. Further increase of the air pressure does not lead to improvement in the engine performance.

In light of results of prior research studies on the operation of two-stroke engines, we were not surprised to discover that for this engine, the performance was most sensitive to the scavenging air pressure. Figure 7 illustrates this sensitivity by displaying the measured IMEP as a function of the intake manifold air pressure. At a low scavenging pressure the engine's performance is degraded - most likely due to poorer mixing because of lower fluid velocities in addition to greater dilution by residual products of combustion. On the other hand, at higher scavenging pressures, the drop in IMEP is likely due to leanness caused by better breathing.

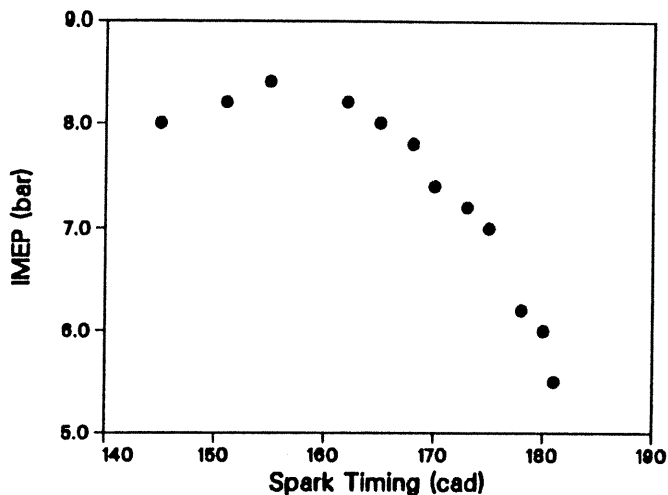

Figure 5. A plot of IMEP as a function of ignition timing for operation at 480 RPM and moderate load, burning methanol.

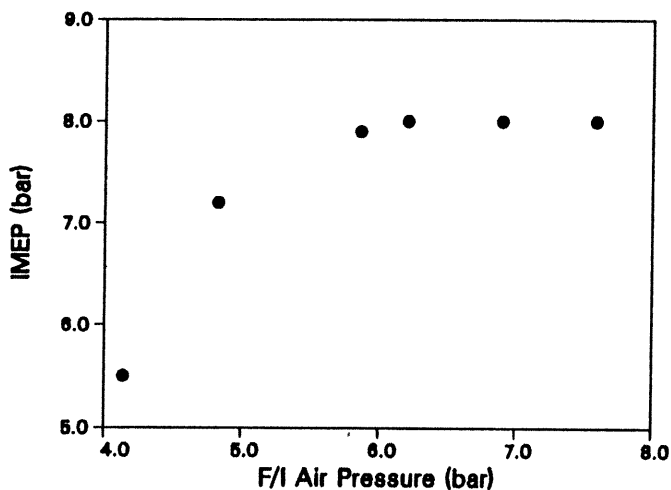

Figure 6. A plot of IMEP as a function of fuel injector air pressure for operation at 480 RPM and moderate load, burning methanol.

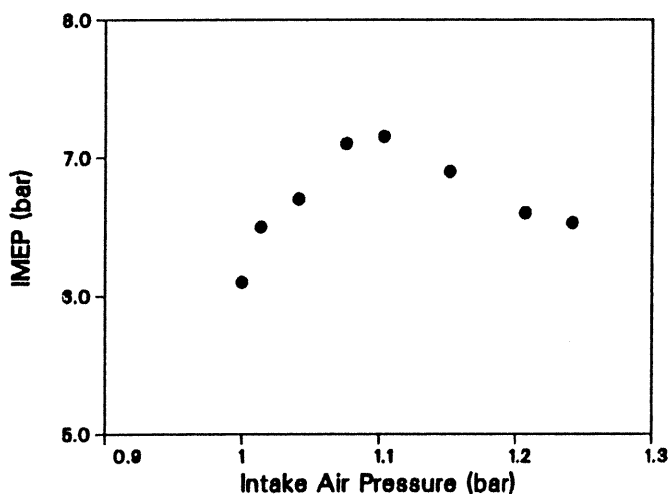

Figure 7. A plot of IMEP as a function of scavenging pressure for operation at 480 RPM and moderate load, burning methanol.

It is interesting to note how small changes in scavenging pressure can lead to significant changes in performance.

INITIAL OBSERVATIONS

To illustrate the capabilities of this research engine, we present some preliminary results of in-cylinder observations using various optical diagnostics. For all of the results described below, we ran the engine at 600 RPM and light load with methanol as fuel.

In Figure 8 we show an image of direct flame emission viewed from beneath the piston. This image was obtained using a high speed video camera/recorder operating at a speed of 2000 frames/sec. The flame luminosity was enhanced by the addition of a small amount of sodium. The field of view in this image is the full aperture available through the piston window which is 75% of the bore diameter. The temporal history of the flame provided by these images indicated that there is very little bulk fluid motion in the horizontal plane during the propagation of the flame.

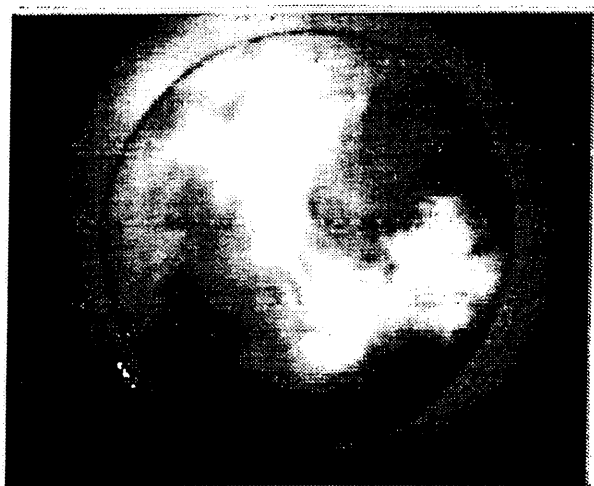

Figure 8. An image of flame luminosity viewed through the piston and recorded at 2000 frames/sec.

Using a standard laser schlieren system and the high speed video camera, we obtained temporal histories of the flame kernel propagation. A typical result of this work is shown in Figure 9. Using two cameras, we recorded orthogonal views simultaneously, at a rate of 6000 frames/sec (time is increasing from top to bottom in Figure. 9). These images were obtained through the round and rectangular windows in the head. We extended the electrodes of the spark plug in order to observe the flame propagating out of the spark gap.

We used the same schlieren setup to observe the fuel spray as illustrated in Figure. 10. This sequence of images gives a qualitative view of the bulk motion of the spray. The images shown in Figure 11 are Mie scattering images of the droplets in the spray. These results were obtained by passing a thin sheet of laser light through the spray, and imaging the light scattered by the droplets on an intensified vidicon camera viewing normal to the laser sheet. Figure 11a is a view when the laser sheet is parallel to the axis of the spray, while Figure. 11b is a view from be-

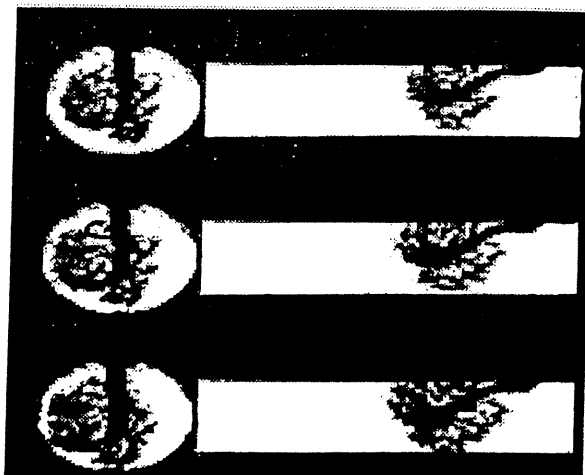

Figure 9. A sequence of orthogonal schlieren images of the initial flame kernel propagation from an extended spark electrode. These images were recorded at 6000 frames/sec.



Figure 10. A sequence of orthogonal schlieren images of the fuel spray. These images were recorded at 6000 frames/sec.

neath the piston with the sheet perpendicular to the axis of the hollow-cone spray. These techniques can highlight large scale characteristics of the flow, and are capable of providing valuable insight into the interaction of the fuel spray with the flowfield.

FUTURE RESEARCH DIRECTIONS

The results presented in the previous sections demonstrate that this new research engine has the potential of being a valuable tool for the study of the fundamental processes occurring in a two-stroke engine. Our investigation of the operating characteristics has indicated that the engine's performance adequately represents the operation of a two-stroke engine. In addition, the optical access should allow us to perform detailed studies of the important in-cylinder phenomena.

Due to the generic nature of this design, the results of our measurements may not be directly applicable to a specific design. Therefore it is necessary to coordinate our



(a)

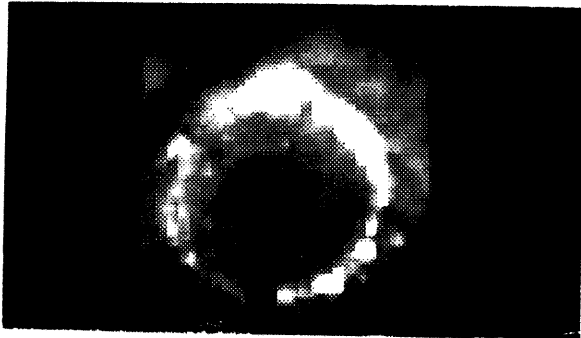

(b)

Figure 11. Planar Mie scattering images of the fuel spray: a) laser sheet parallel to the axis of the spray, and viewed through the rectangular window in the head; b) laser sheet normal to the axis of the spray, and viewed through the window in the piston.

experiments with three-dimensional numerical modeling, as a means of coupling our results into new engine designs. To that end we will direct our studies toward the measurement of conditions in the transfer ports along with the characteristics of the cylinder-port inflow jets. This information can then be used as boundary and initial conditions for numerical model calculations. Along with this, we intend to make measurements of the velocity fields, both during scavenging and prior to combustion, to provide data with which comparisons to the model results can be made in order to verify the adequacy of the models.

The interaction of the fuel spray with the scavenging flow is another important area requiring study. The characteristics and dynamics of the spray, along with the vaporization and mixing of the fuel are very important aspects of engine design. We intend to use planar imaging techniques to acquire information about the nature of these processes. This work should also lead to a better understanding of fuel stratification in the combustion chamber, and how this can affect the combustion process. The ability of new two-stroke engines to meet exhaust emission requirements and remain reasonably fuel efficient will depend strongly on understanding the fuel stratification problem.

Finally, the residual products of combustion are an integral part of the operation of a two-stroke engine. If we can add to the current understanding of the effects of residuals, engine designers should be able to improve the overall characteristics of the engine. This is a ripe area for in-

vestigation, and our new research engine, along with some of the more advanced diagnostic techniques such as degenerate four-wave mixing (10) could lead us toward a better understanding of these problems and ultimately, better two-stroke cycle engine designs.

ACKNOWLEDGEMENTS

The authors would like to thank Axel zur Loye, Chris Edwards, Dave Rakestraw, and Dennis Siebers for their helpful interactions in this project and in the preparation of this paper. We also wish to recognize the invaluable technical assistance of Duane Sunnarborg during the construction and installation of the research engine. In addition, we would like to thank Mark McConkie and Marie-Joseph Cottureau for their assistance in getting the experiment operating. Finally, we wish to thank CORIA, the University of Rouen for the support of B.J. Cousyn during his visit at Sandia.

REFERENCES

1. Ferguson, C.R., *Internal Combustion Engines, Applied Thermosciences*, John Wiley & Sons, 1986.
2. Heywood, J.B., *Internal Combustion Engine Fundamentals*, McGraw-Hill Book Co., 1988.
3. Sato, T. and Nakayama, M., "Gasoline Direct Injection for a Loop-Scavenged Two-Stroke Cycle Engine," SAE Paper No. 870172, SAE Int. Cong. and Exp., 1988.
4. Duret, P., Ecomard, A. and Audinet, M., "A New Two-Stroke Engine with Compressed-Air Assisted Fuel Injection for High Efficiency Low Emissions Applications," SAE Paper No. 880176, SAE Int. Cong. and Exp., 1988.
5. Jante, A., "Scavenging and Other Problems of Two-Stroke Cycle Spark-Ignition Engines," SAE Paper No. 680-468, SAE Int. Cong. and Exp., 1968.
6. Blair, G.P., "The Correlation of Theory and Experiment for Scavenging Flow in Two-Stroke Cycle Engines," SAE Paper No. 881265, SAE Int. Cong. and Exp., 1988.
7. Sher, E., "Modeling the Scavenging Process in the Two-Stroke Engine-An Overview," SAE Paper No. 890414, SAE Int. Cong. and Exp., 1989.
8. Smyth, J.G., Kenny, R.G. and Blair, G.P., "Motored and Steady Flow Boundary Conditions Applied to the Prediction of Scavenging Flow in a Loop Scavenged Two-Stroke Cycle Engine," SAE Paper No. 900800, SAE Int. Cong. and Exp., 1988.
9. Emerson, J., Felton P.G. and Bracco, F.V., "Structure of Sprays from Fuel Injectors Part III: The Ford Air-Assisted Fuel Injector," SAE Paper No. 900478, SAE Int. Cong. and Exp., 1990.
10. Dreier, T. and Rakestraw, D.J., "Measurement of OH Rotational Temperatures in a Flame Using Degenerate Four-wave Mixing," *Optics Letters*, 15, 1, 1990.